

























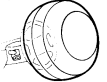











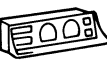

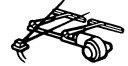

## SYSTEM INDEX

1996 Model (Location No. 1 to 28)

SYSTEMS	LOCATION	SYSTEMS	LOCATION	SYSTEMS	LOCATION
ABS	 11-2	Fog Light	 9-1	Radio and Player	 21-2 (w/ CD Player) 22-2 (w/o CD Player)
ABS and Traction Control	 10-2	Fuel Lid Opener	 19-1	Rear Window Defogger and Mirror Heater	 16-3
Auto Antenna	 21-8 (w/ CD Player) 22-4 (w/o CD Player)	Headlight and Light Auto Turn Off	 6-2 (USA) 7-2 (Canada)	Remote Control Mirror	 12-3 (w/ Memory) 12-2 (w/o Memory)
Automatic Air Conditioning	 25-2	Horn	 15-1	Seat Heater	 16-1
Automatic Glare-Resistant EC Mirror	 20-3	Ignition	 1-6 (1UZ-FE) 1-7 (2JZ-GE)	Shift Lock	 17-1
Automatic Light Control	 28-2	Illumination	 6-7 (USA) 27-2 (Canada)	SRS	 17-3
Back-Up Light	 4-8 (1UZ-FE) 5-8 (2JZ-GE)	Interior Light	 8-2	Starting	 1-3
Cellular Mobile Telephone	 23-2	Moon Roof	 14-2	Taillight and Stop Light	 6-5 (USA) 7-7 (Canada)
Charging	 1-2	Power Seat (1UZ-FE and 2JZ-GE w/ Driving Position Memory)	 13-5	Theft Deterrent and Door Lock Control	 19-2
Cigarette Lighter	 16-4	Power Seat (2JZ-GE w/o Driving Position Memory)	 26-2	Turn Signal and Hazard Warning Light	 9-3
Combination Meter	 24-2	Power Seat (Passenger's) and Electric Tension Reducer	 13-7	Unlock and Seat Belt Warning	 6-4 (USA) 7-6 (Canada)
Cruise Control	 18-2	Power Source	 1~28-1	Wiper and Washer	 15-2
Electronically Controlled Transmission and A/T Indicator	  4-2 (1UZ-FE) 5-2 (2JZ-GE)	Power Tilt and Power Telescopic	 13-2	Wireless Door Lock Control	 19-7
Electronically Controlled Hydraulic Cooling Fan (1UZ-FE)	 20-2	Power Window	 14-3		
Engine Control	 2-2 (1UZ-FE) 3-2 (2JZ-GE)	PPS	 17-2		

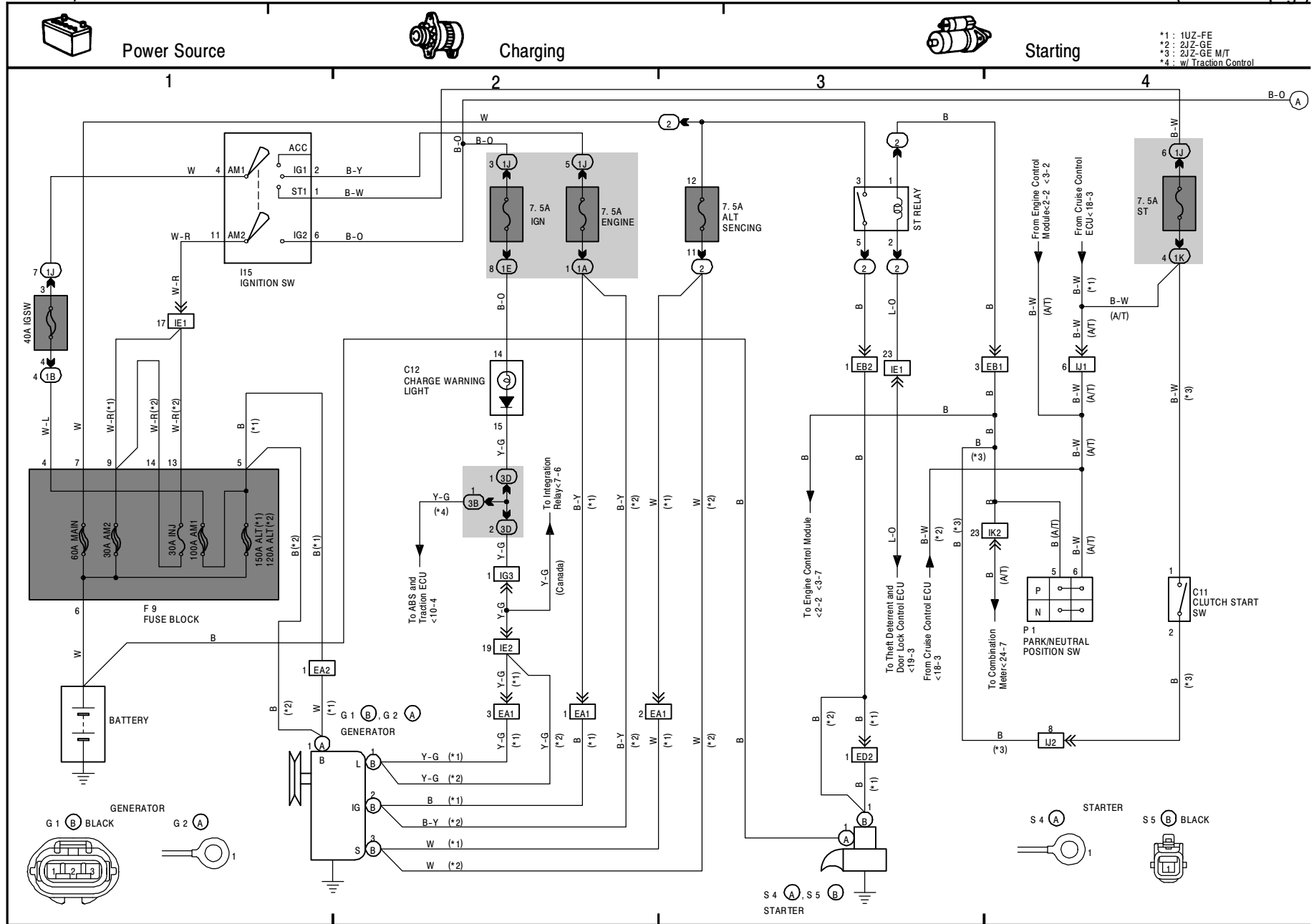

- \*1 : 1UZ-FE
- \*2 : 2JZ-GE
- \*3 : 2JZ-GE M/T
- \*4 : w/ Traction Control

1 SC400/SC300(Cont' d)

Ignition(1UZ-FE)

Ignition(2JZ-GE)

\*1 : 1UZ-FE  
\*2 : 2JZ-GE

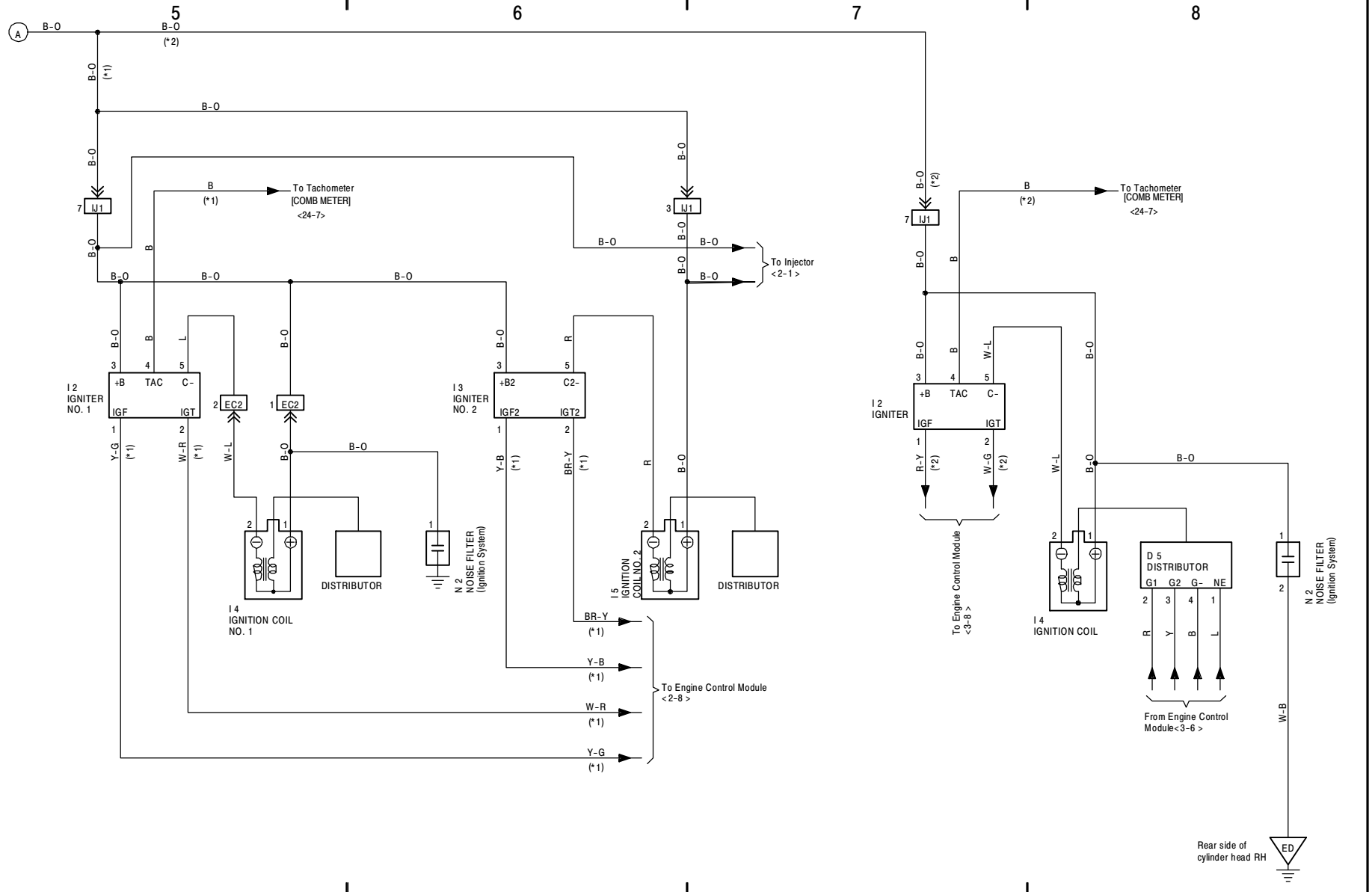

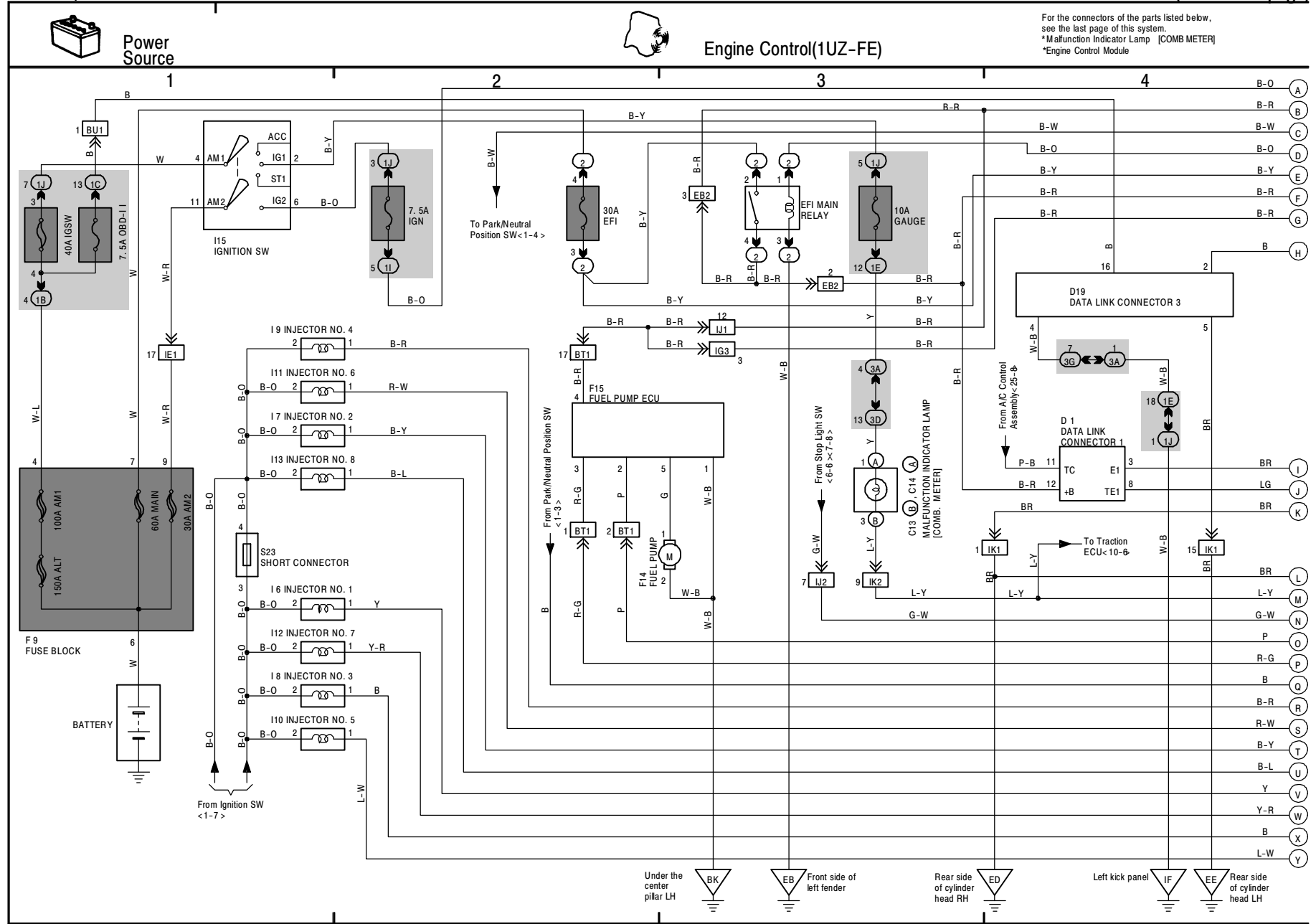



Engine Control(1UZ-FE)

For the connectors of the parts listed below, see the next page.  
 \*Mallunction Indicator Lamp [COMB METER] \*Engine Control Module

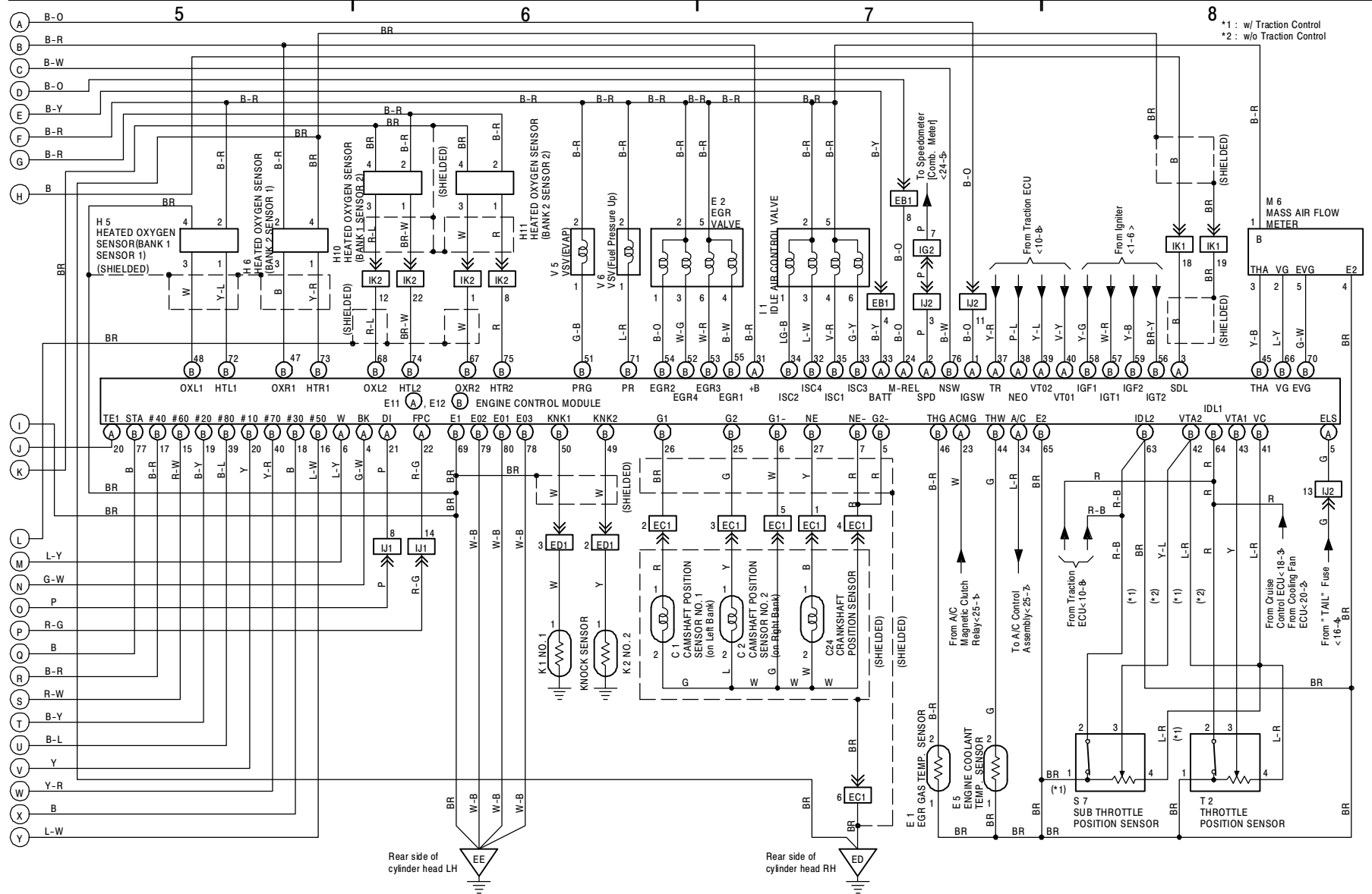



Engine Control(1UZ-FE)

9

10

11

12

MALFUNCTION INDICATOR LAMP  
(COMB. METER)

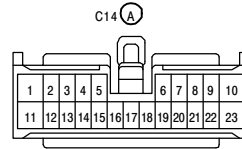
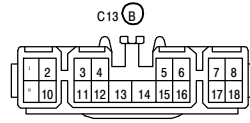

ENGINE CONTROL MODULE

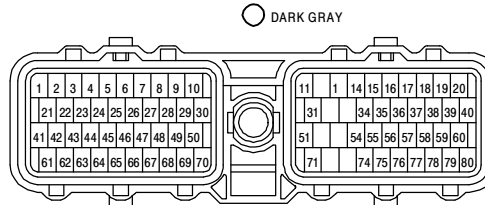



Power Source



Engine Control(2JZ-GE)

For the connectors of the parts listed below, see the last page of this system  
 \*Malfunction Indicator Lamp (COMB METER)  
 \*Engine Control Module

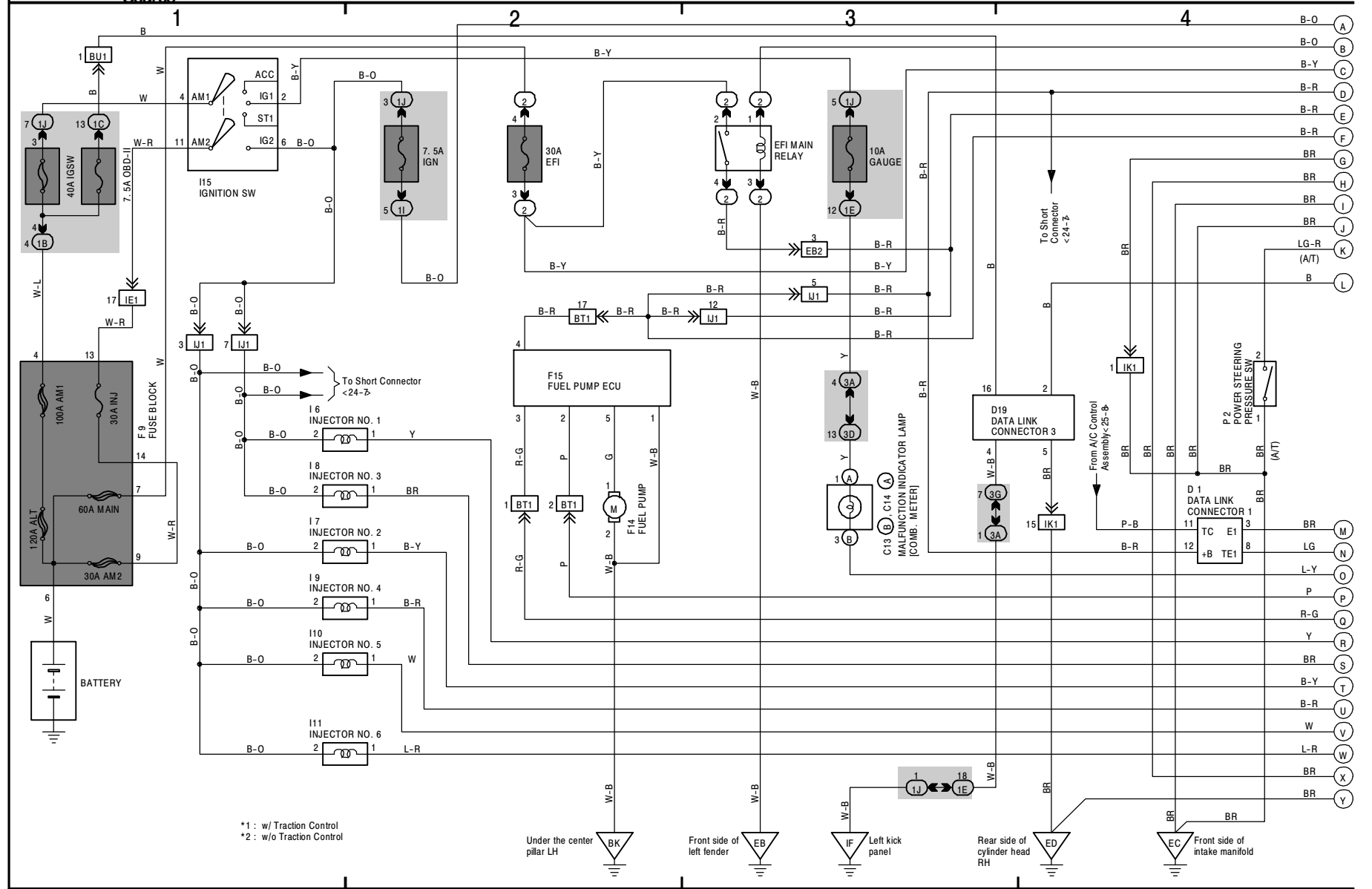



Engine Control(2JZ-GE)

For the connectors of the parts listed below, see the next page.  
 \* Malfunction Indicator Lamp [COMB METER]  
 \* Engine Control Module

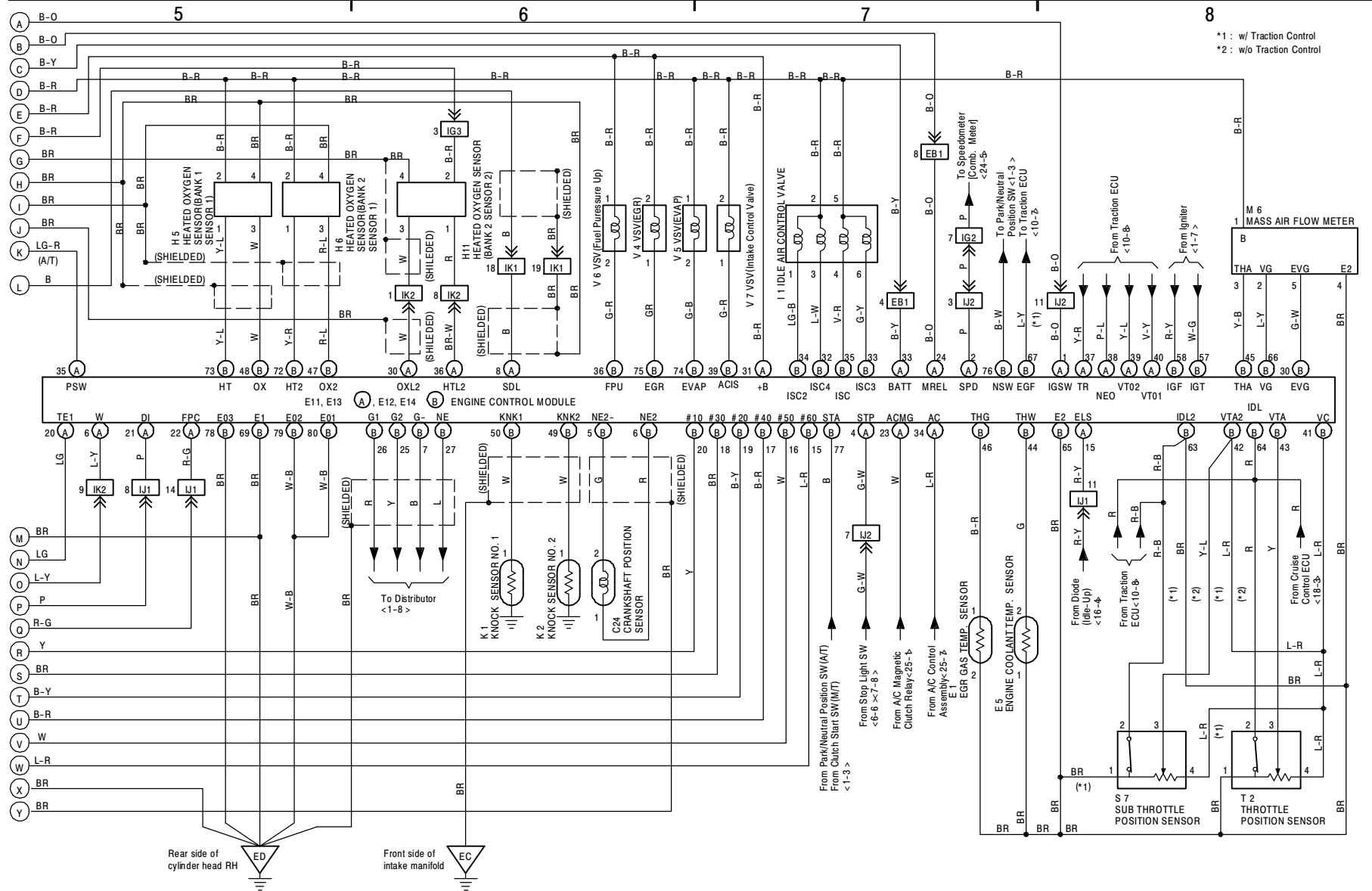

\*1 : w/ Traction Control  
 \*2 : w/o Traction Control





Engine Control(2JZ-GE)

9

10

11

12

MALFUNCTION INDICATOR LAMP  
(COMB. METER)

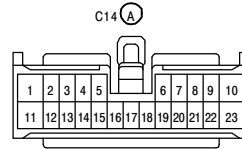
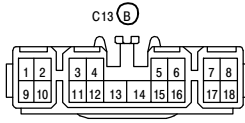

ENGINE CONTROL MODULE

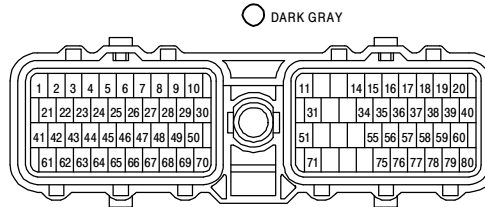

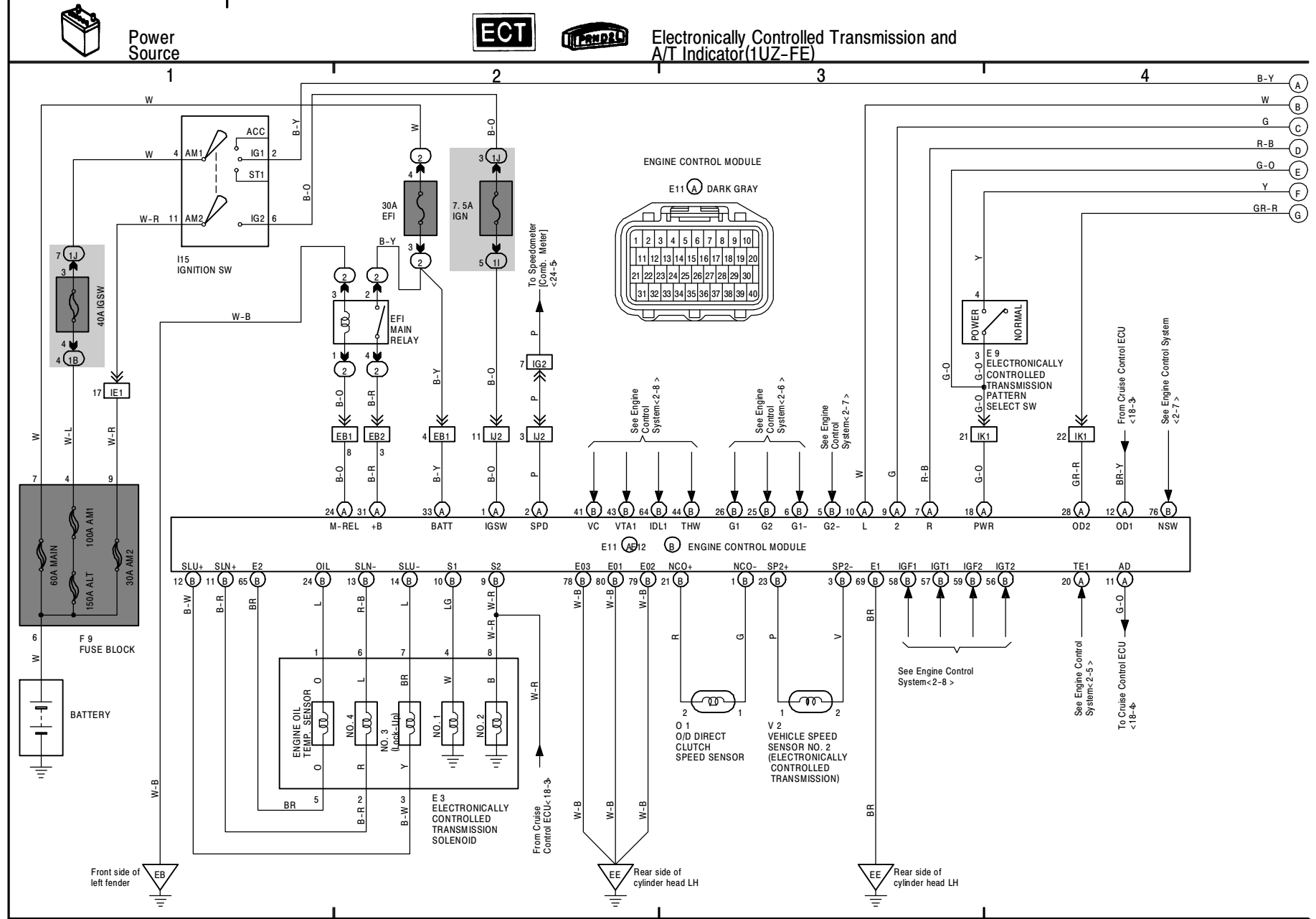

4 SC400/SC300(Cont' d)



Electronically Controlled Transmission and A/T Indicator(1UZ-FE)



Back-Up Light(1UZ-FE)

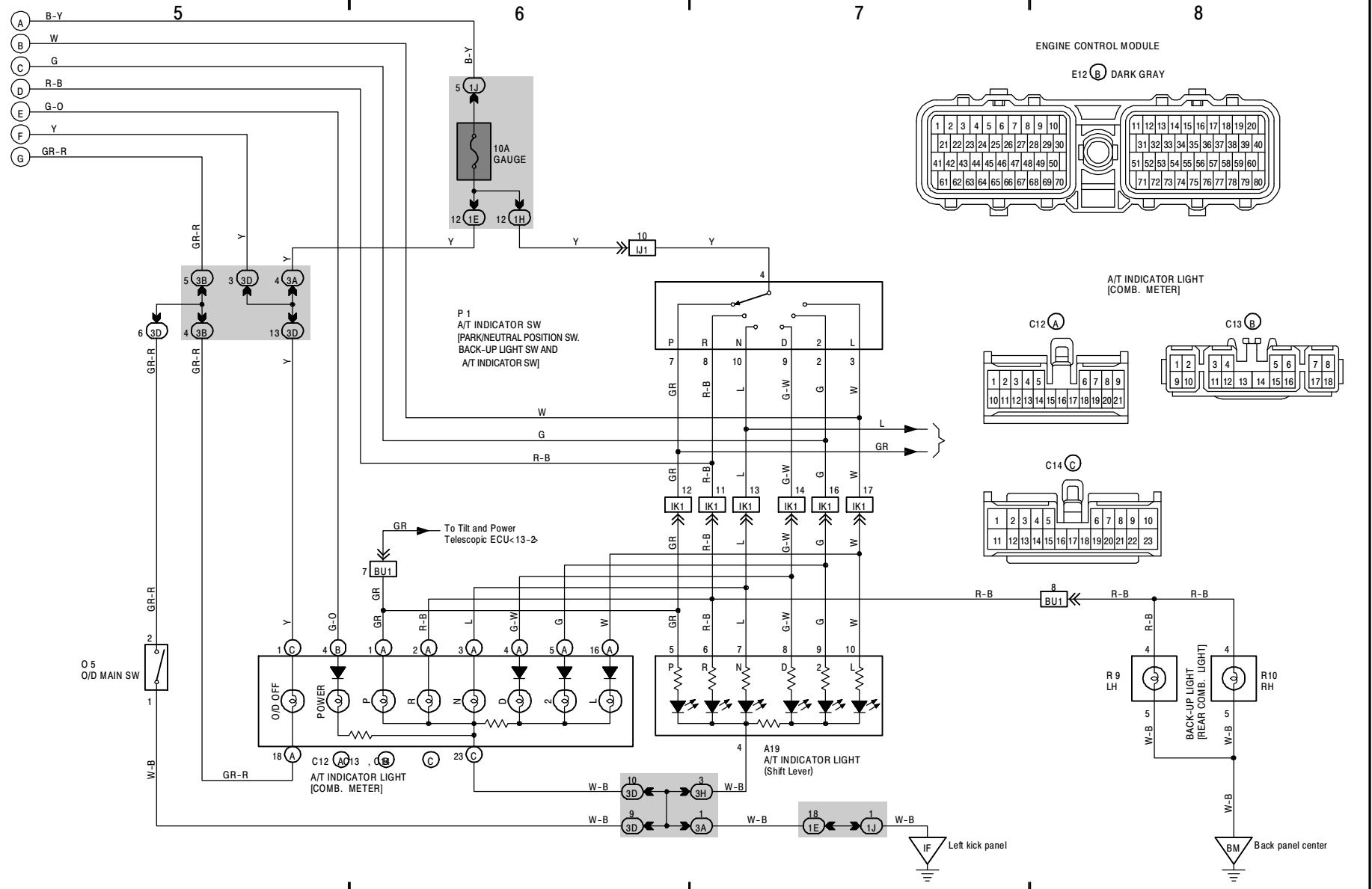



5 SC400/SC300(Cont' d)



Electronically Controlled Transmission and A/T Indicator(2JZ-GE)



Back-Up Light (2JZ-GE)

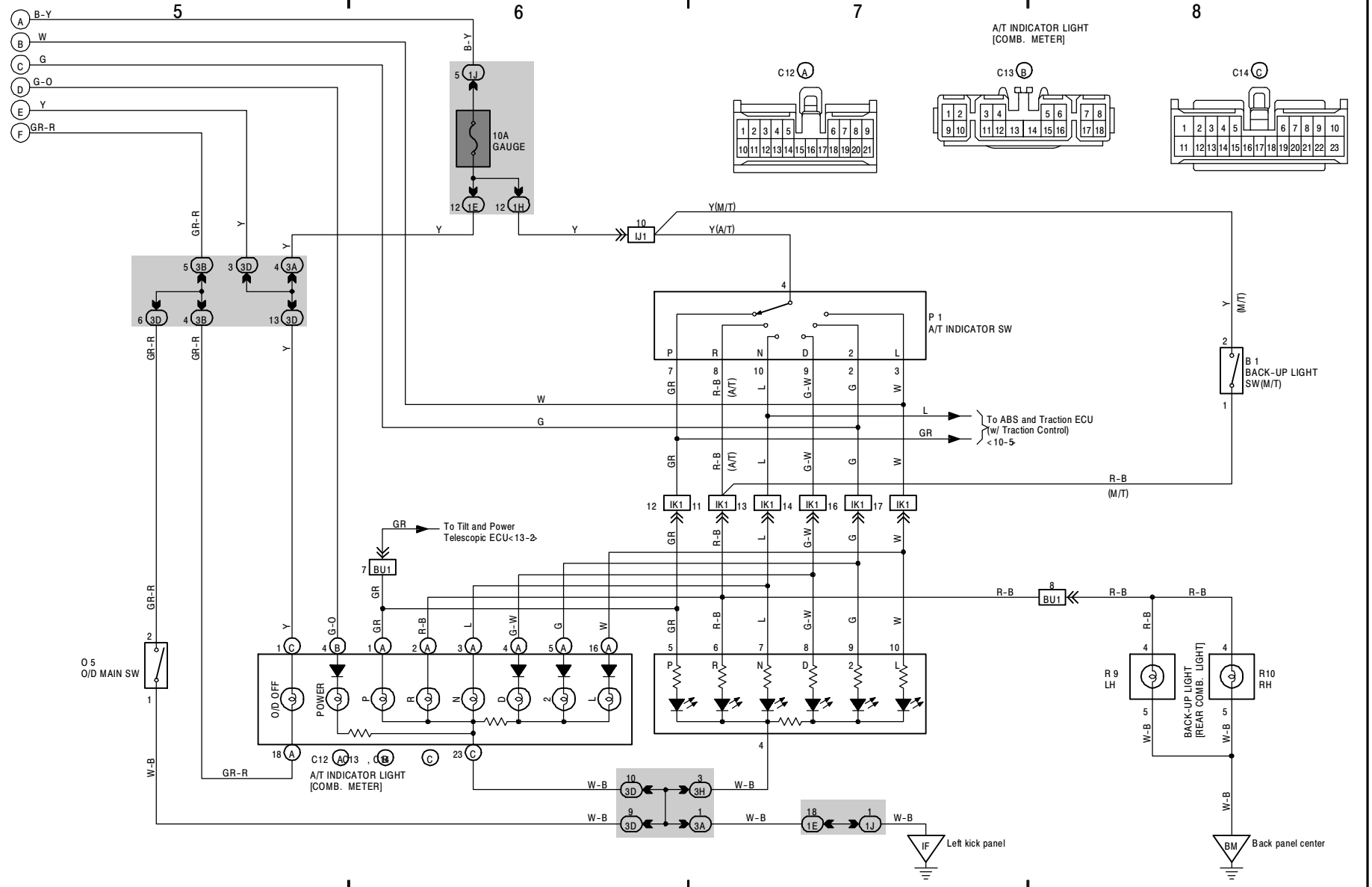







Power Source



Headlight and Light Auto Turn Off(Canada)

\*1: 1UJ-FE  
\*2: 2UJ-GE

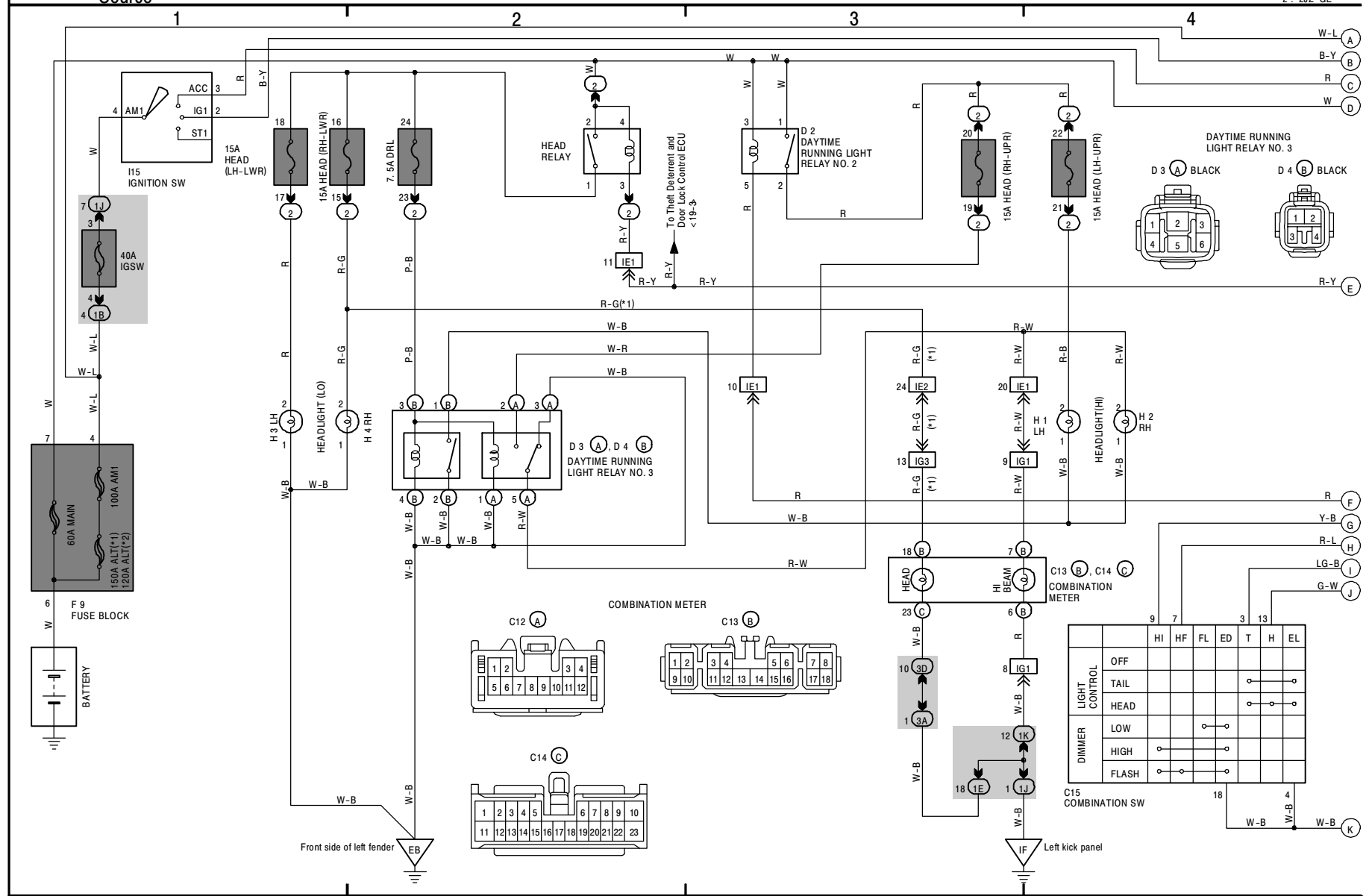

7 SC400/SC300(Cont' d)



Unlock and Seat Belt Warning(Canada)



Taillight and Stop Light(Canada)

\*2: w/ Memory Power Seat  
 \*3: w/o Memory Power Seat

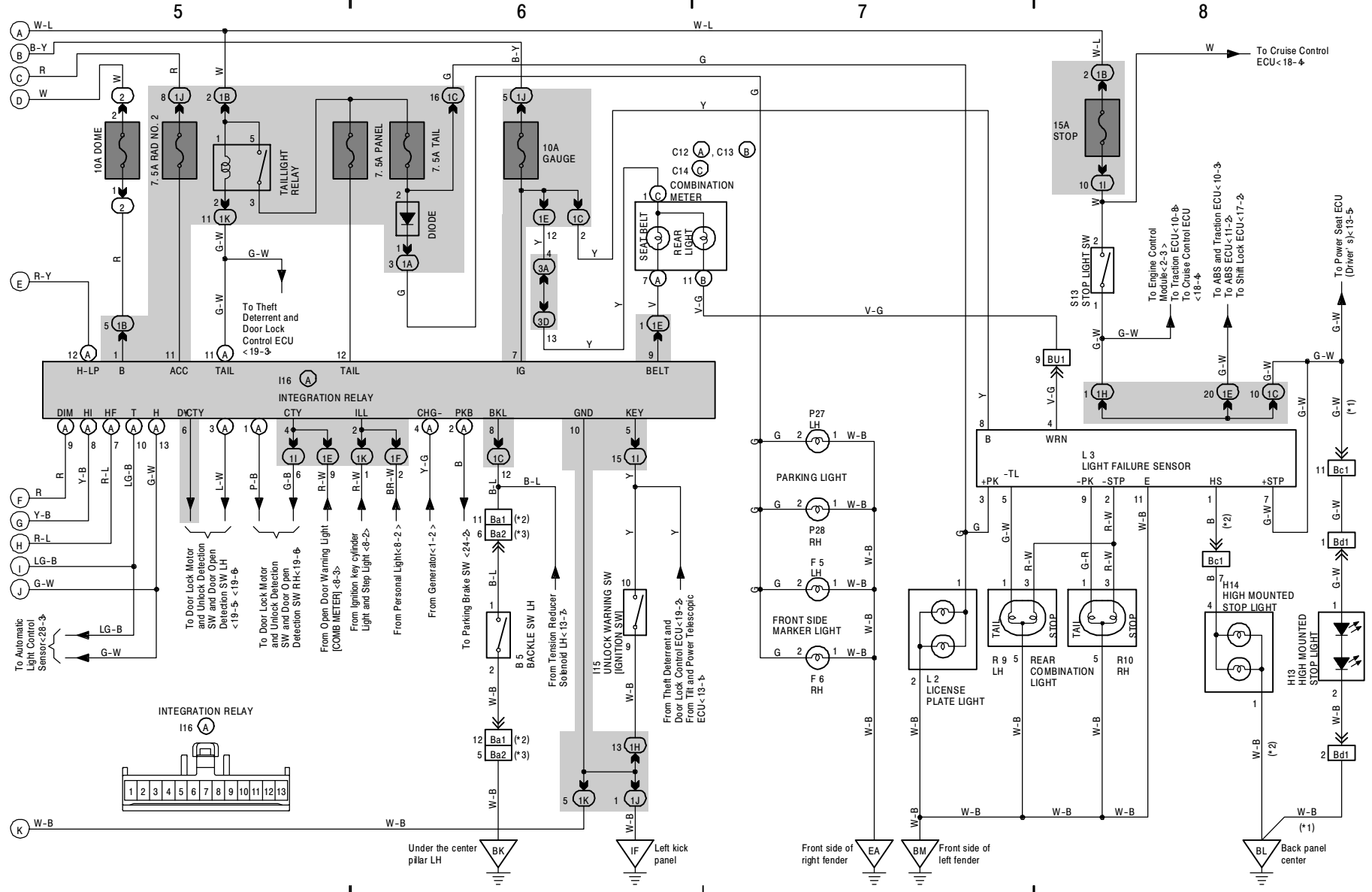

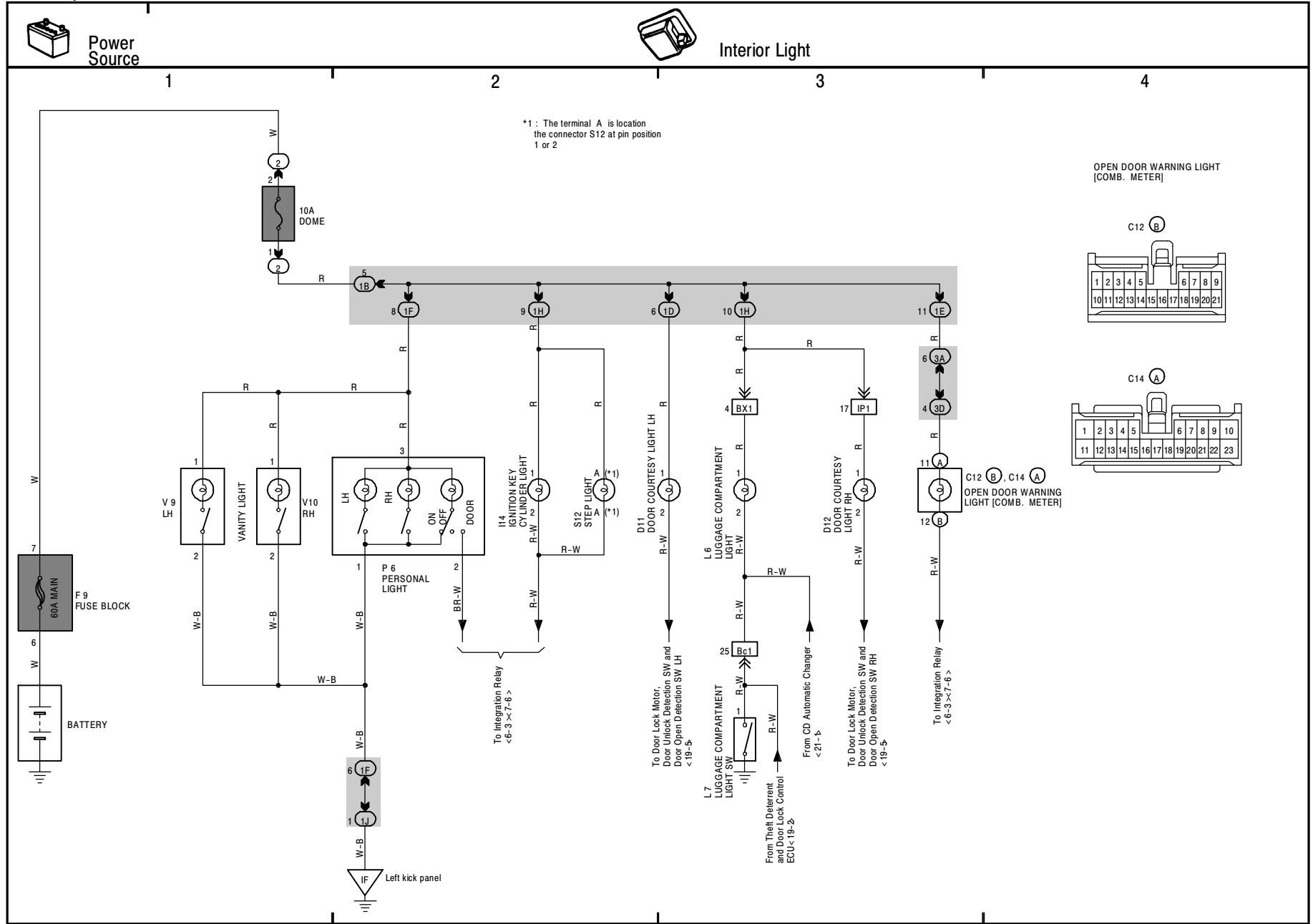





Power Source



**TRAC**

ABS and Traction Control

For the connectors of the parts listed below, see the last page of this system.  
 \*ABS Actuator \*ABS and Traction ECU  
 \*Combinatin Meter \*Traction Brake Actuator  
 \*Traction ECU

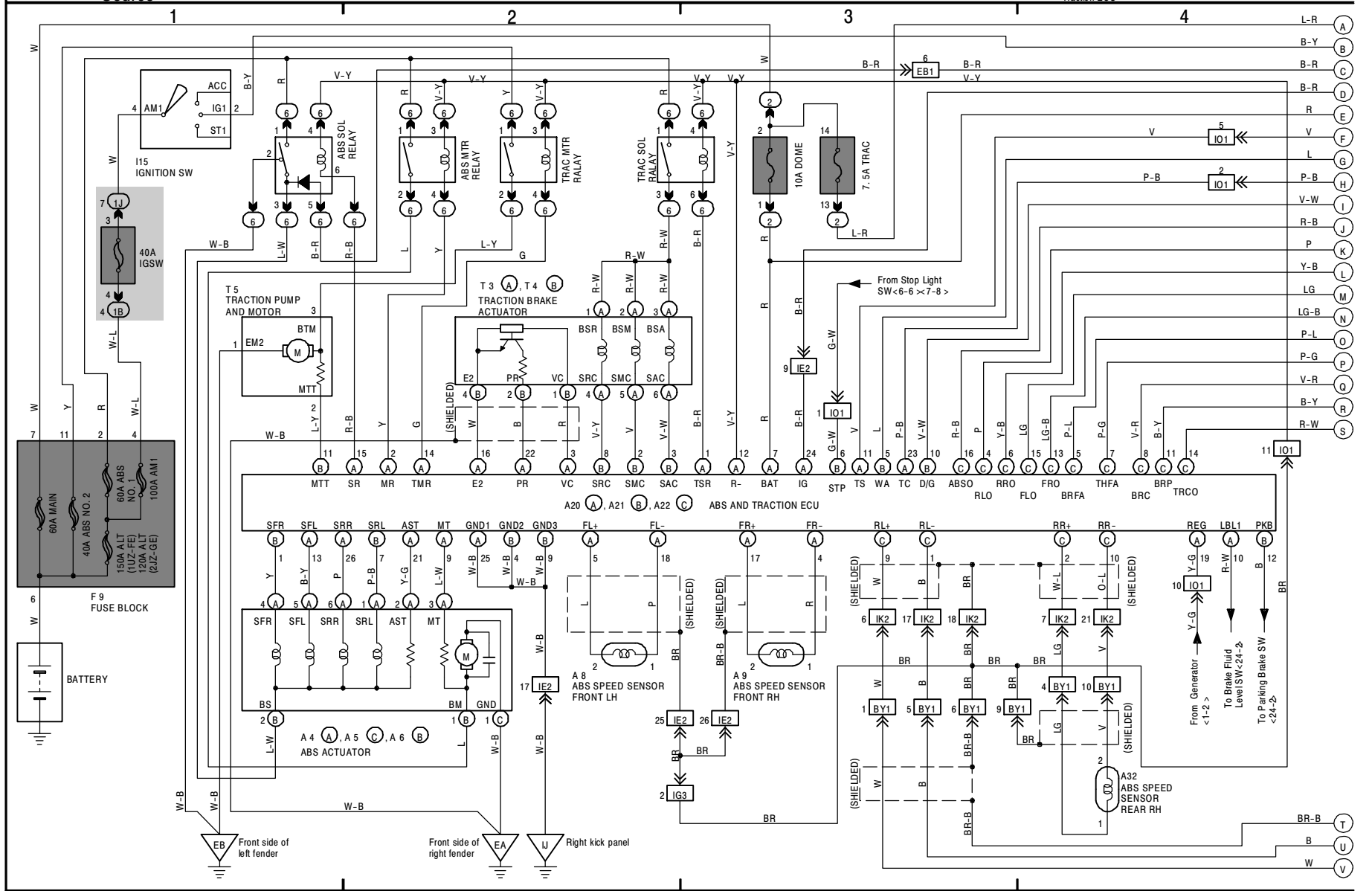





ABS and Traction Control

9

10

11

12

ABS ACTUATOR



ABS AND TRACTION ECU

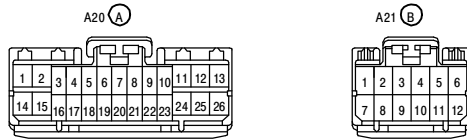

TRACTION ECU

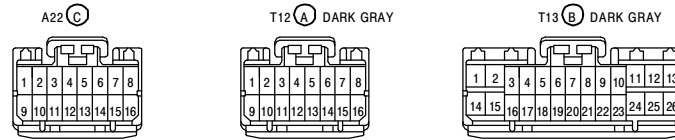

COMBINATION METER

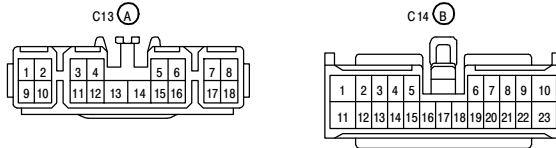

TRACTION BRAKE ACTUATOR

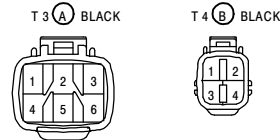



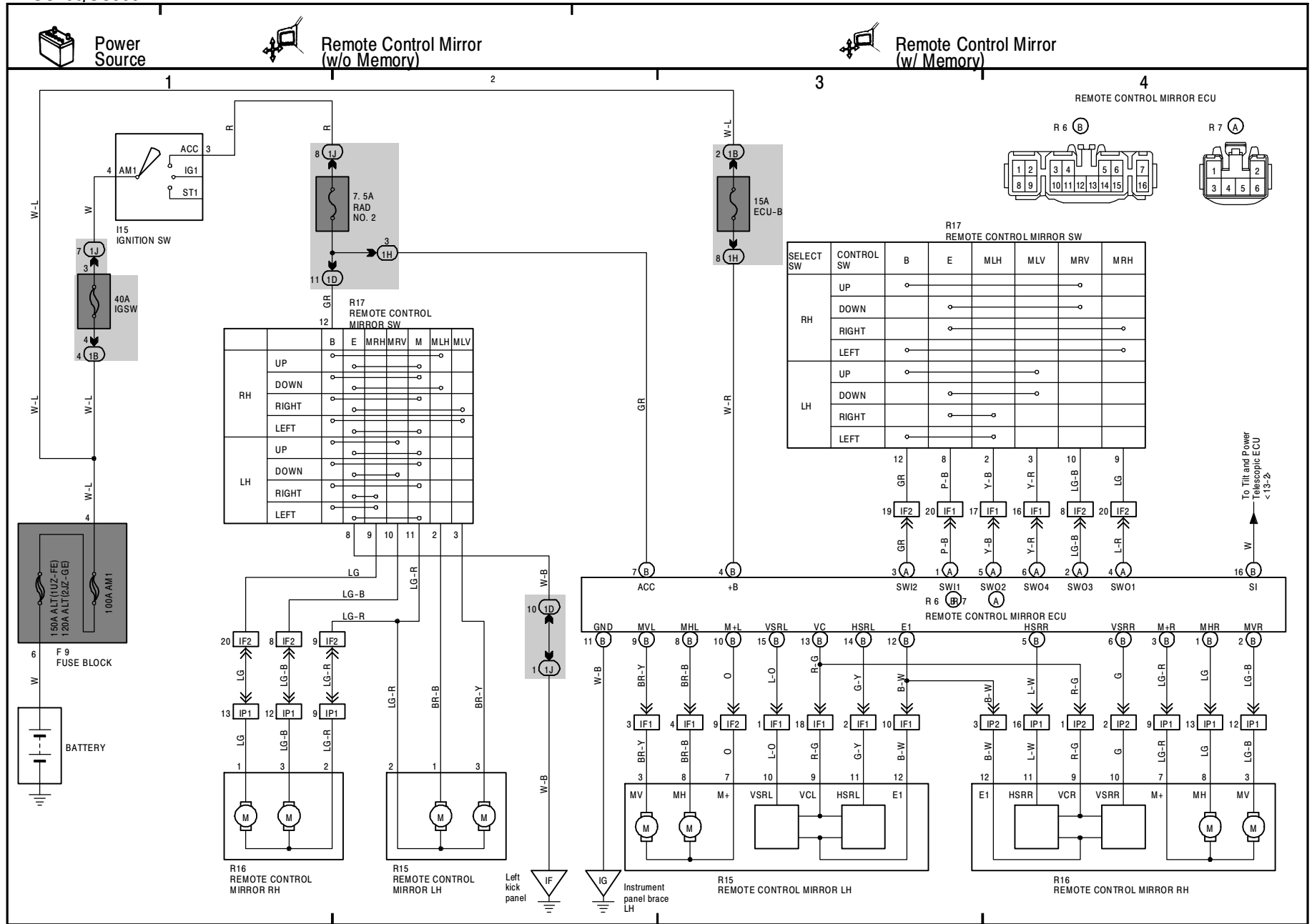



13 SC400/SC300(Cont' d)



Power Seat(w/ Driving Position Memory)



Power Seat(Passenger' s) and Electric Tension Reducer

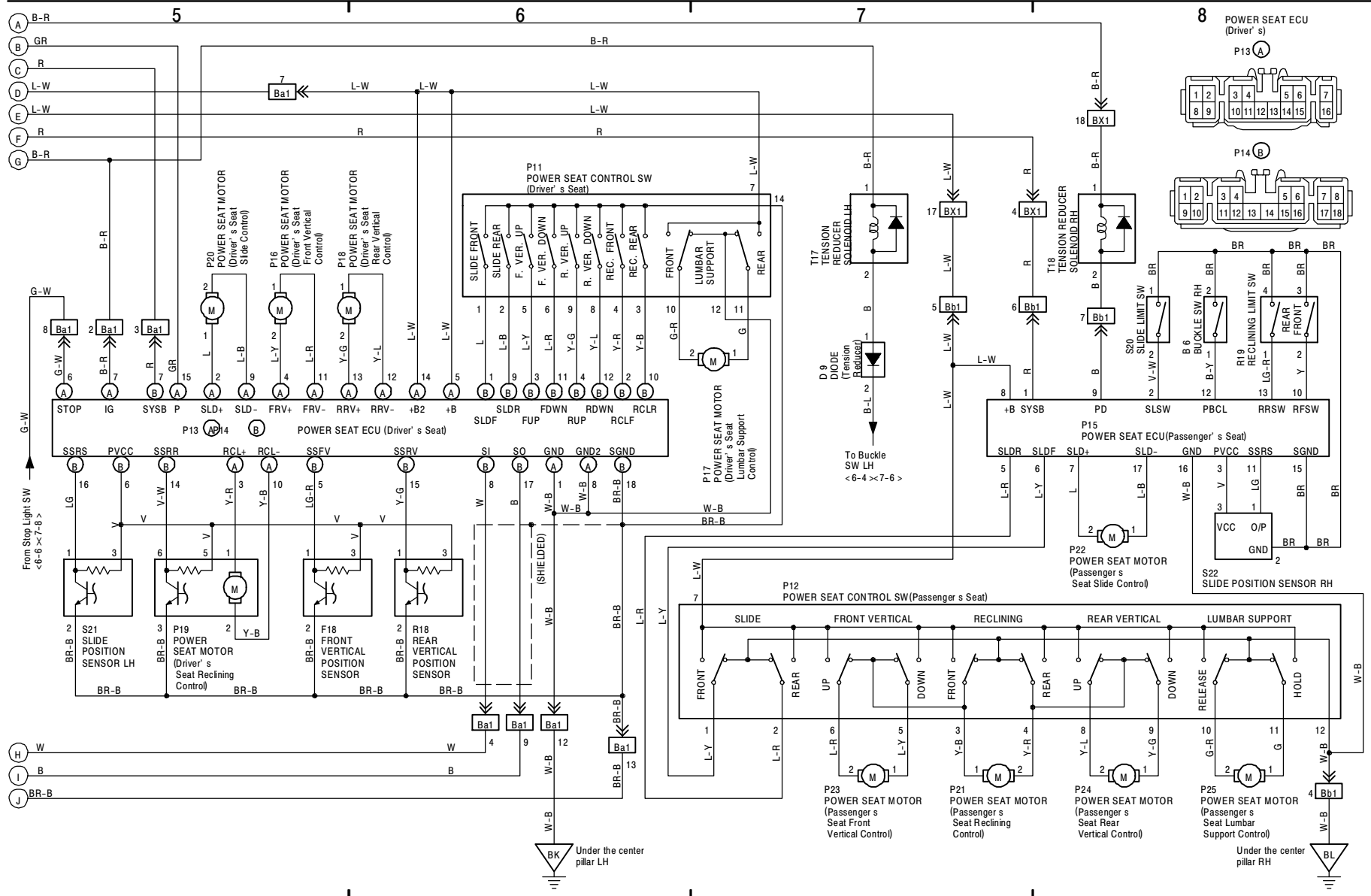

14 SC400/SC300

K OVERALL ELECTRICAL WIRING DIAGRAM

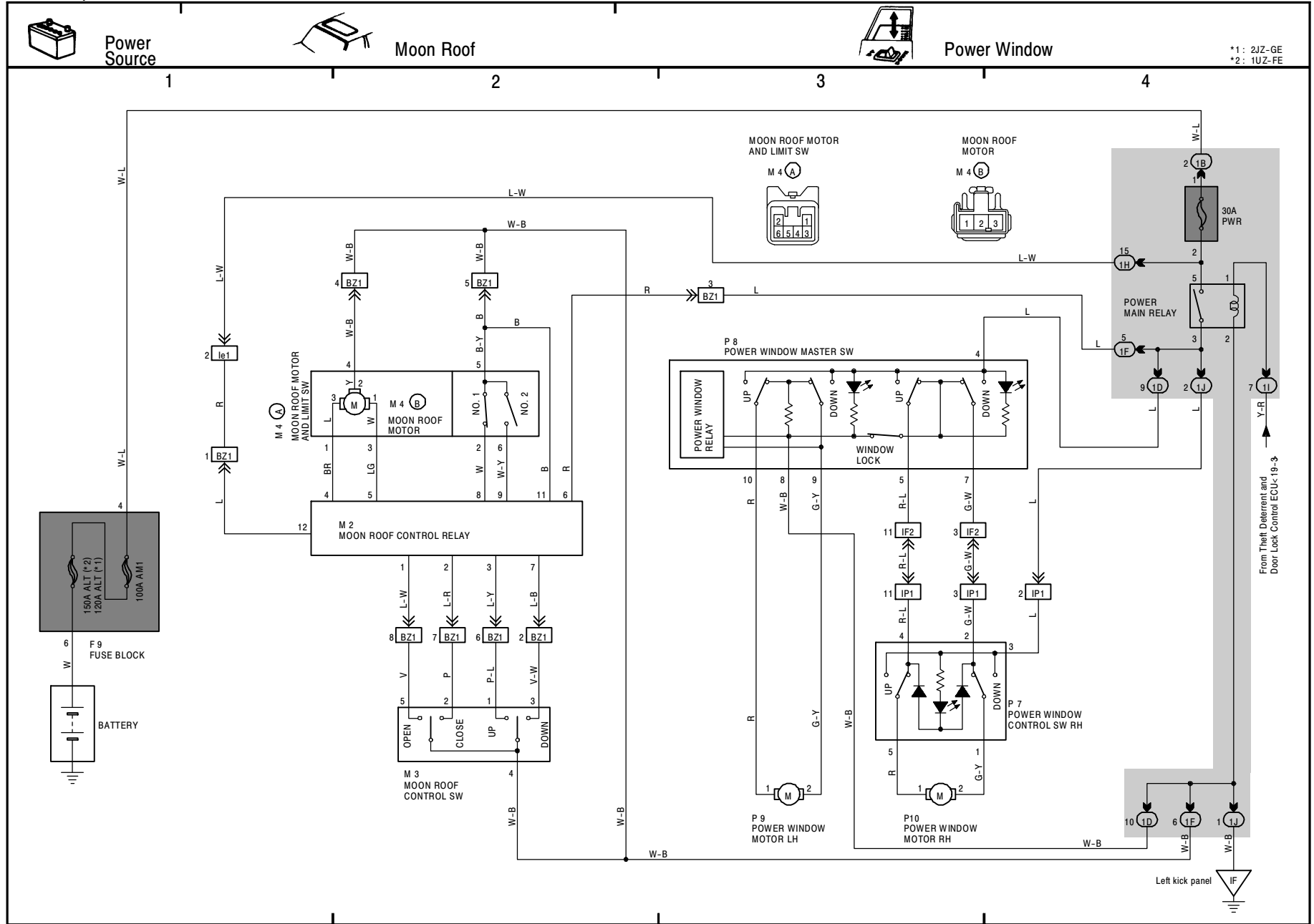

\*1: 2JZ-GE  
\*2: 1UZ-FE

From Theft Deterrent and Door Lock Control ECU-19-3

Left kick panel

# 15 SC400/SC300

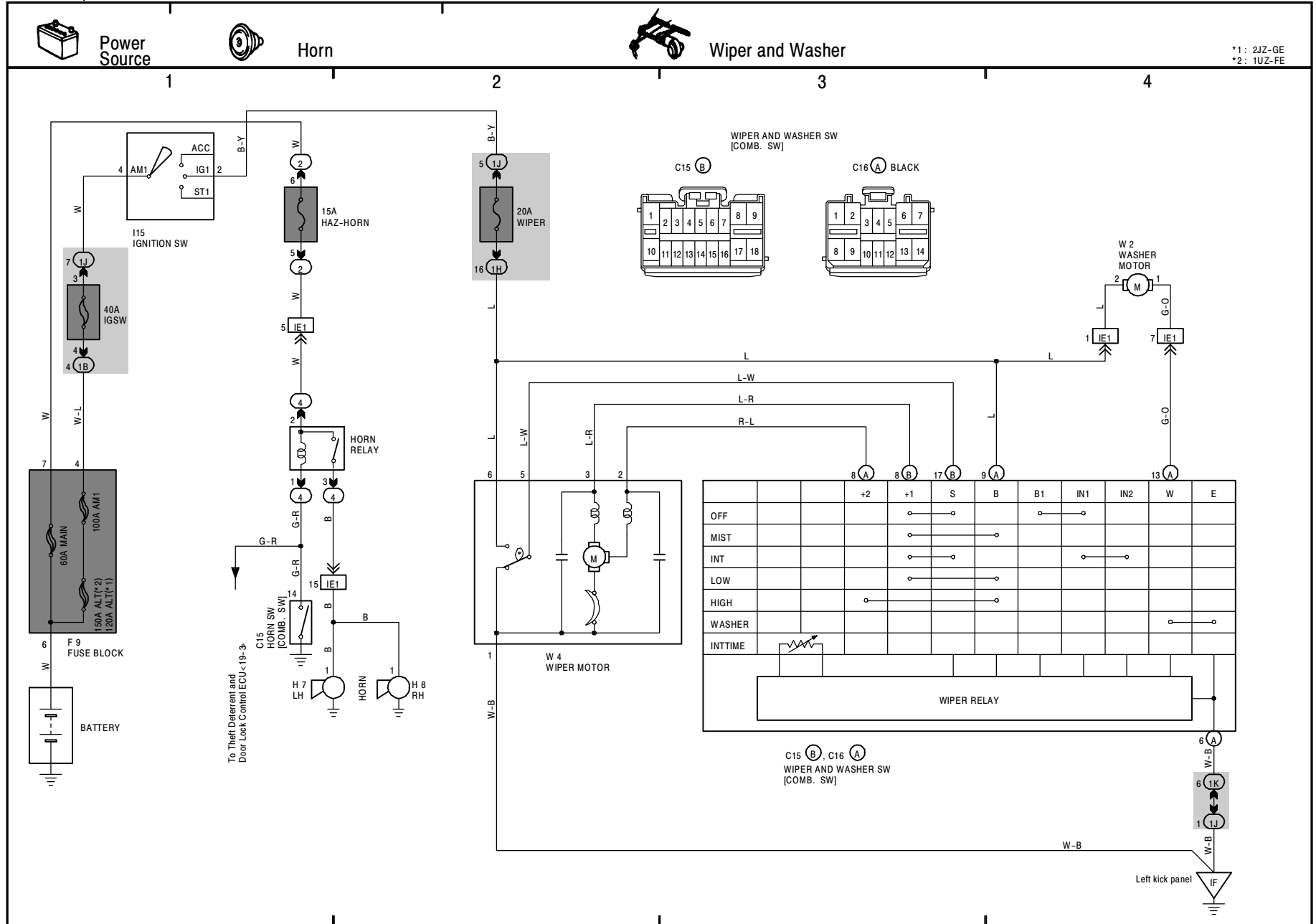

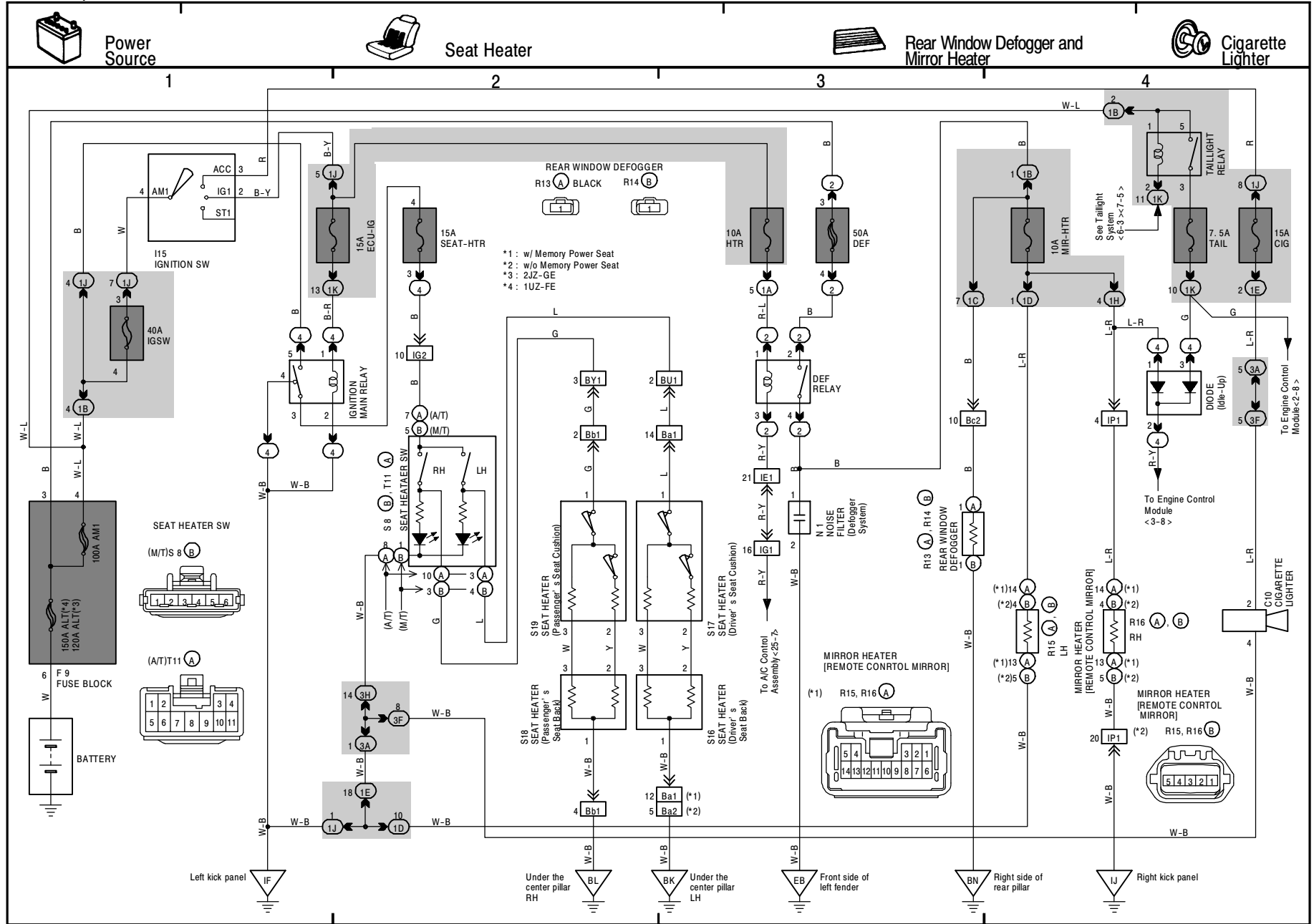



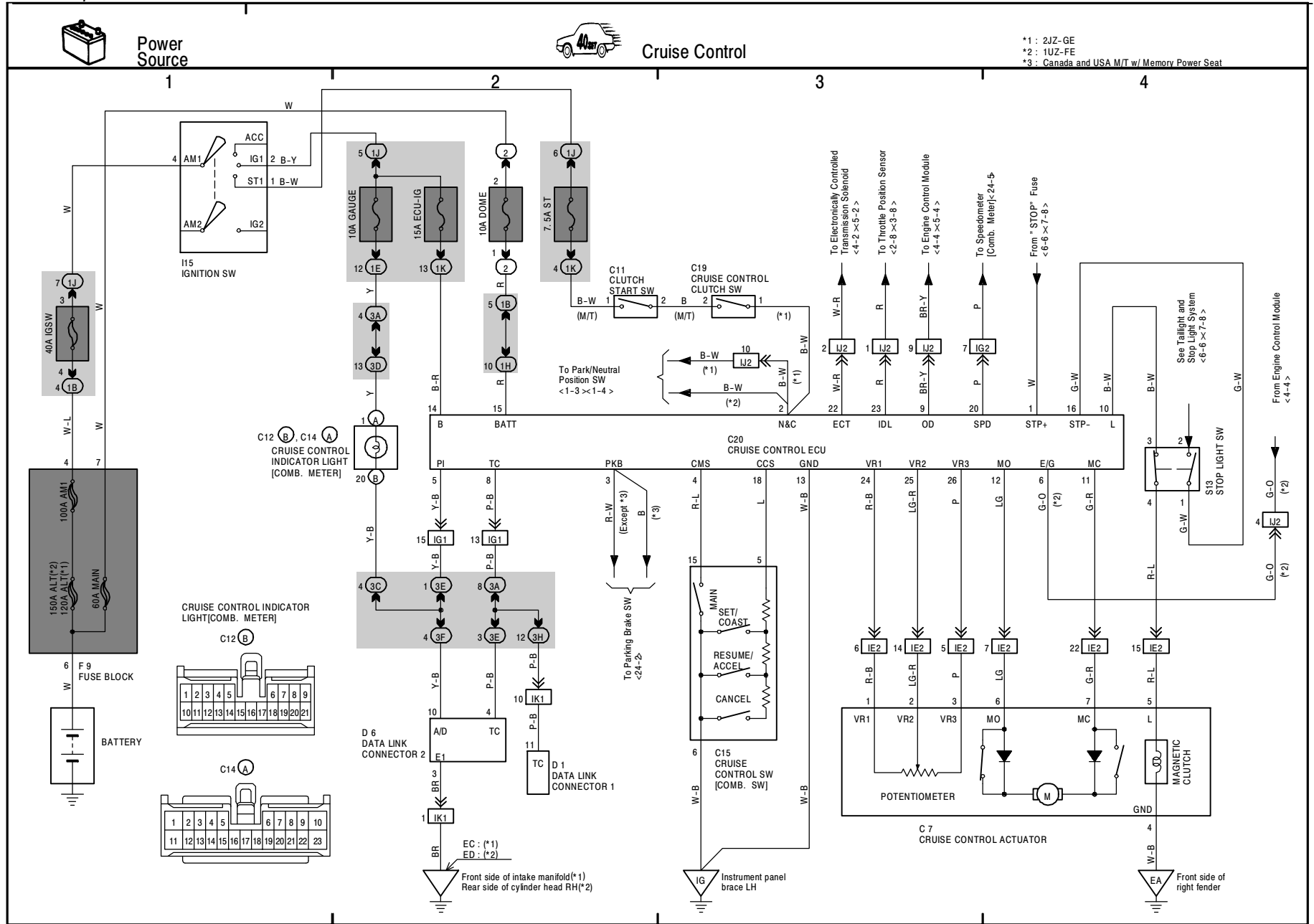

\*1 : 2JZ-GE  
 \*2 : 1UZ-FE  
 \*3 : Canada and USA M/T w/ Memory Power Seat

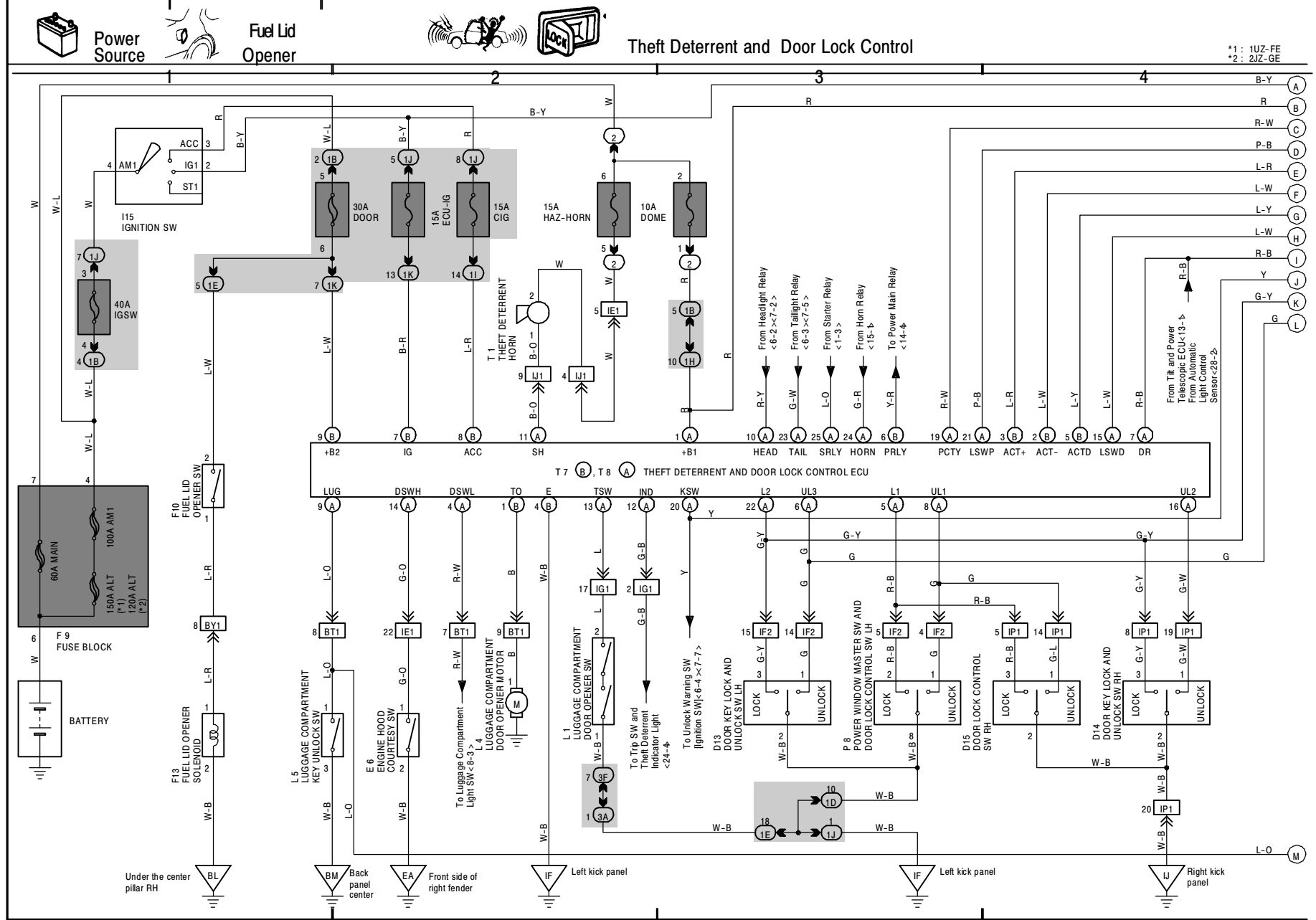

19 SC400/SC300(Cont' d)



Theft Deterrent and Door Lock Control



Wireless Door Lock Control

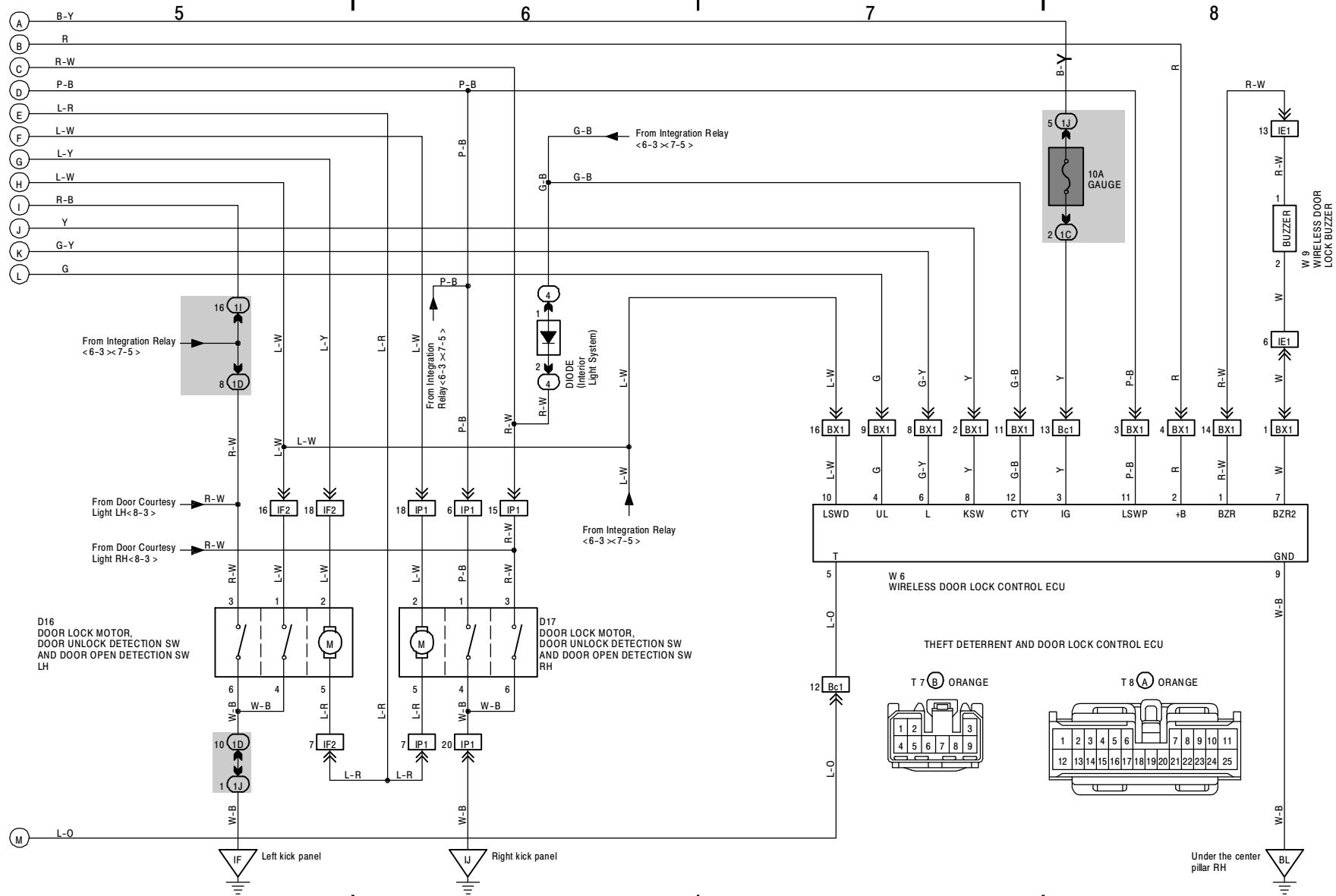





Power Source



Radio and Player(w/ CD Player)

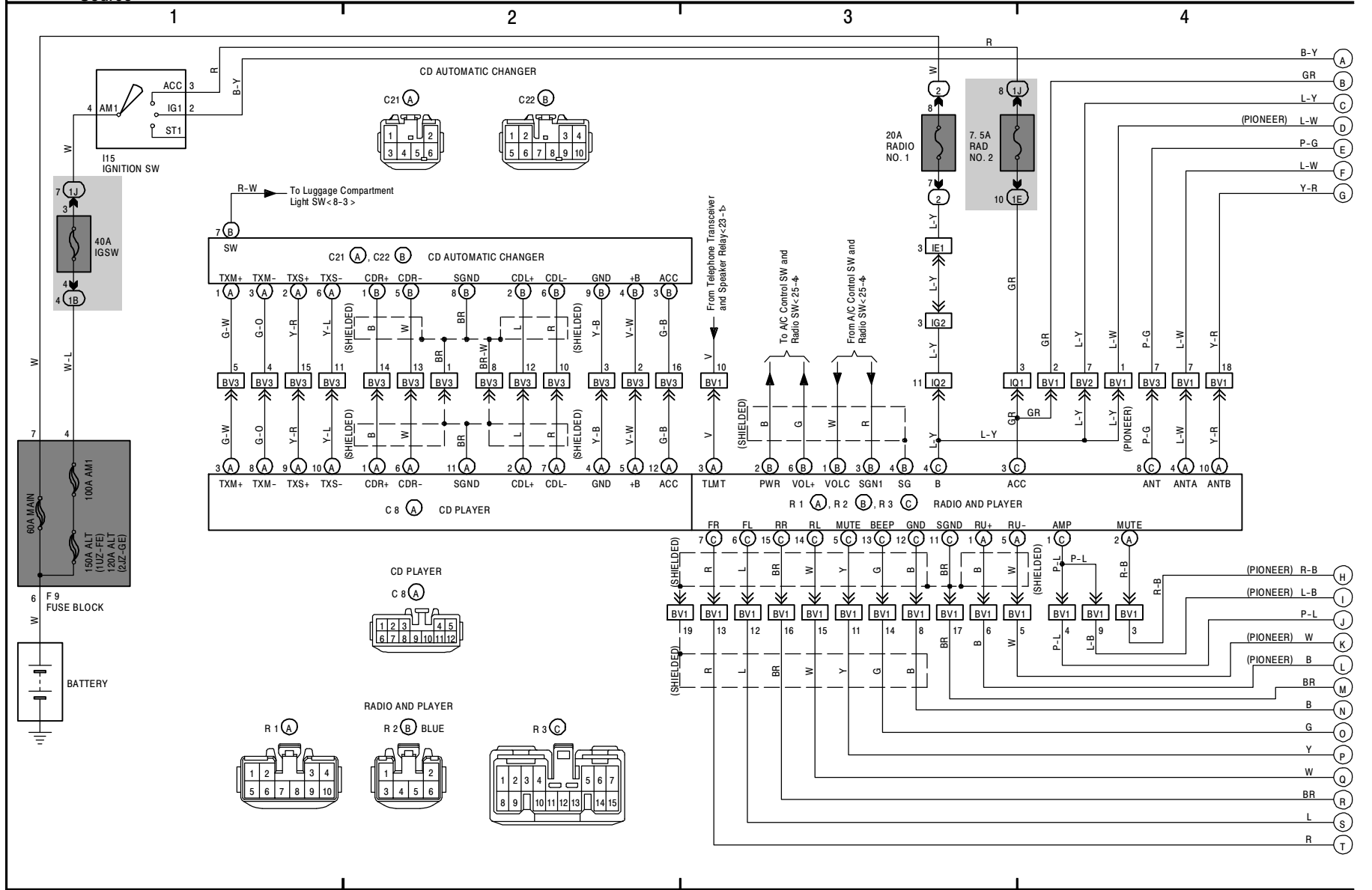

21 SC400/SC300(Cont' d)



Radio and Player(w/ CD Player)



Auto Antenna(w/ CD Player)

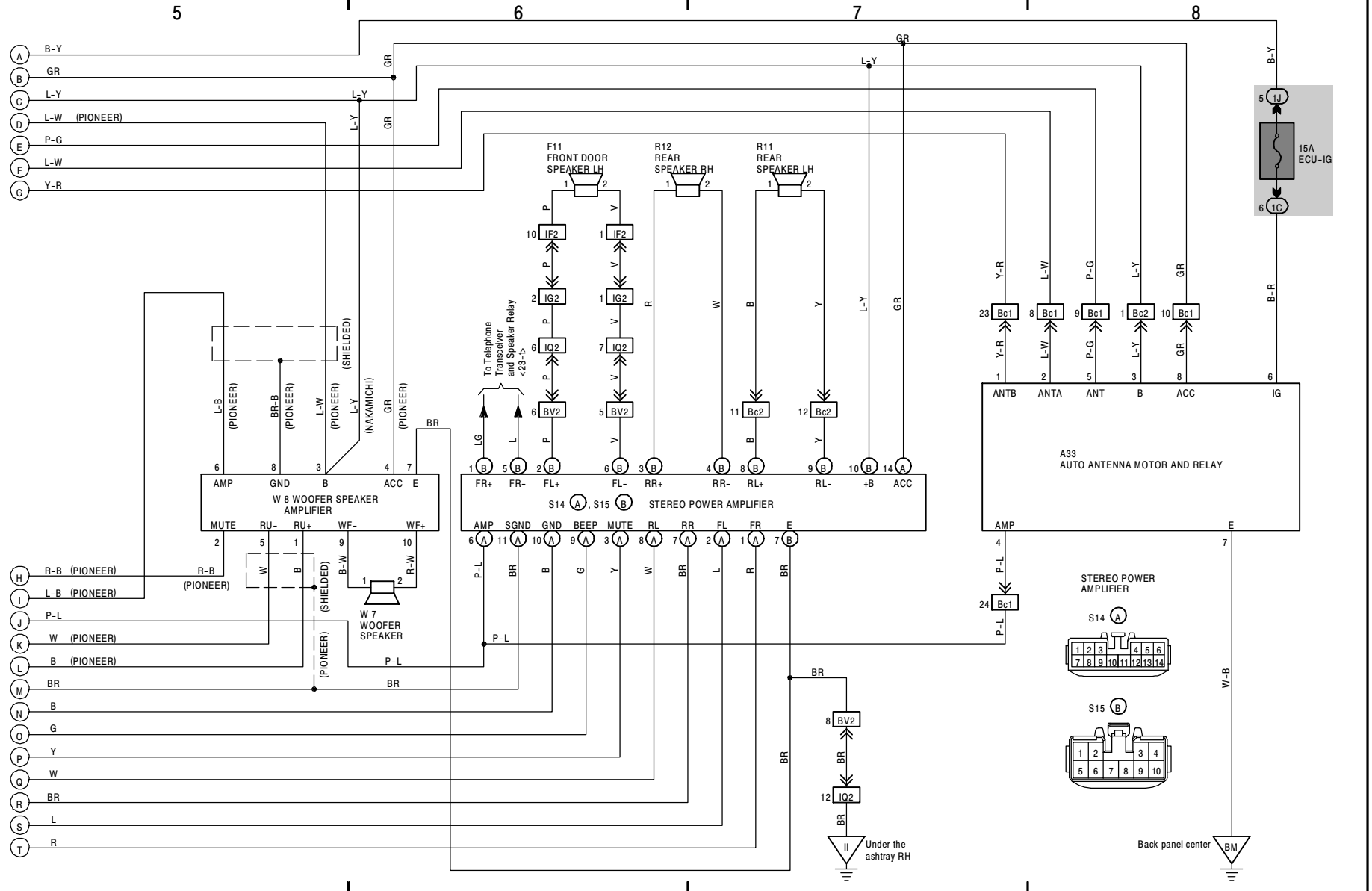





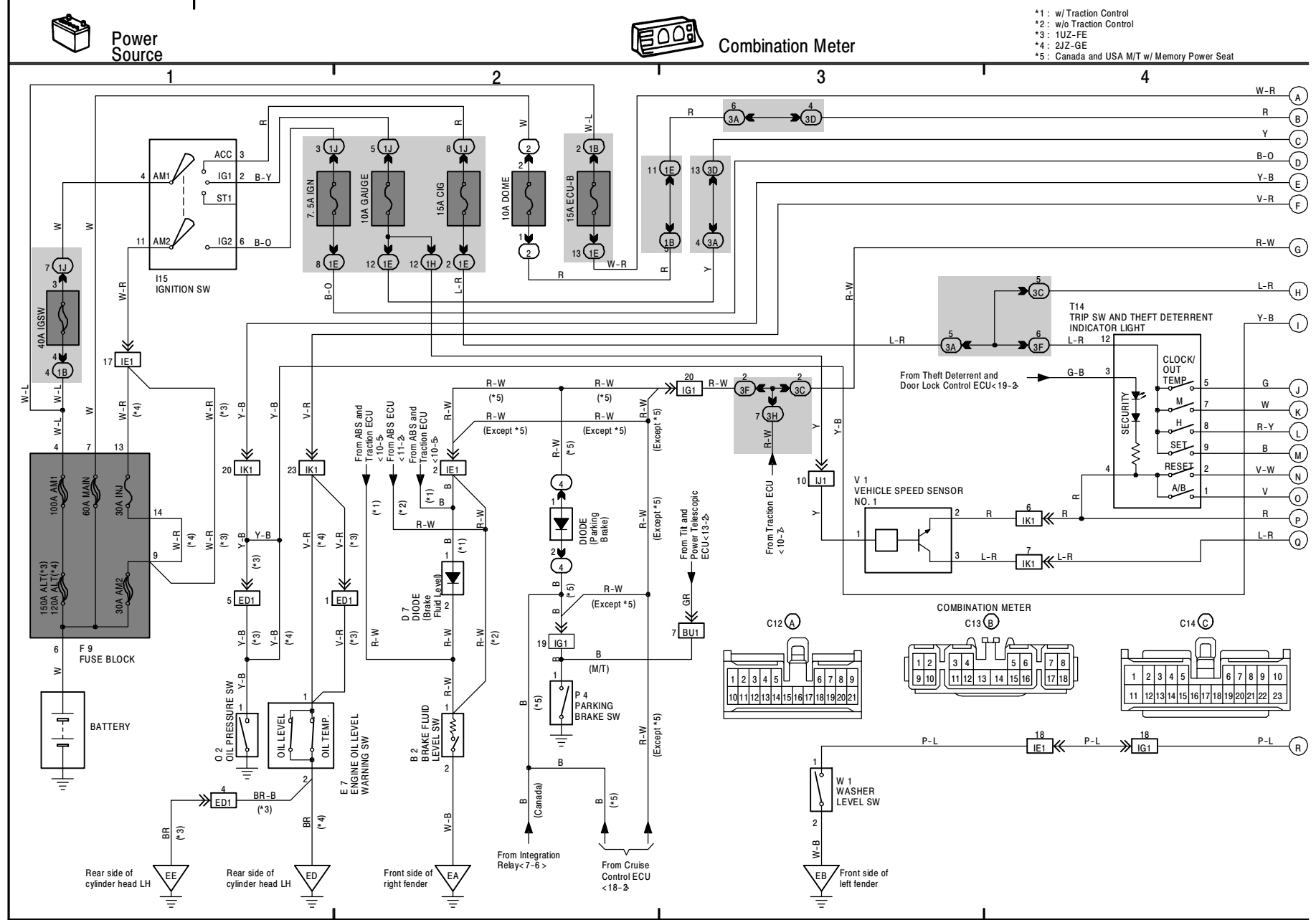

24 SC400/SC300(Cont' d)



Combination Meter

- \*2 : Malfunction Indicator Lamp
- \*3 : 1UZ-FE
- \*4 : 2JZ-GE

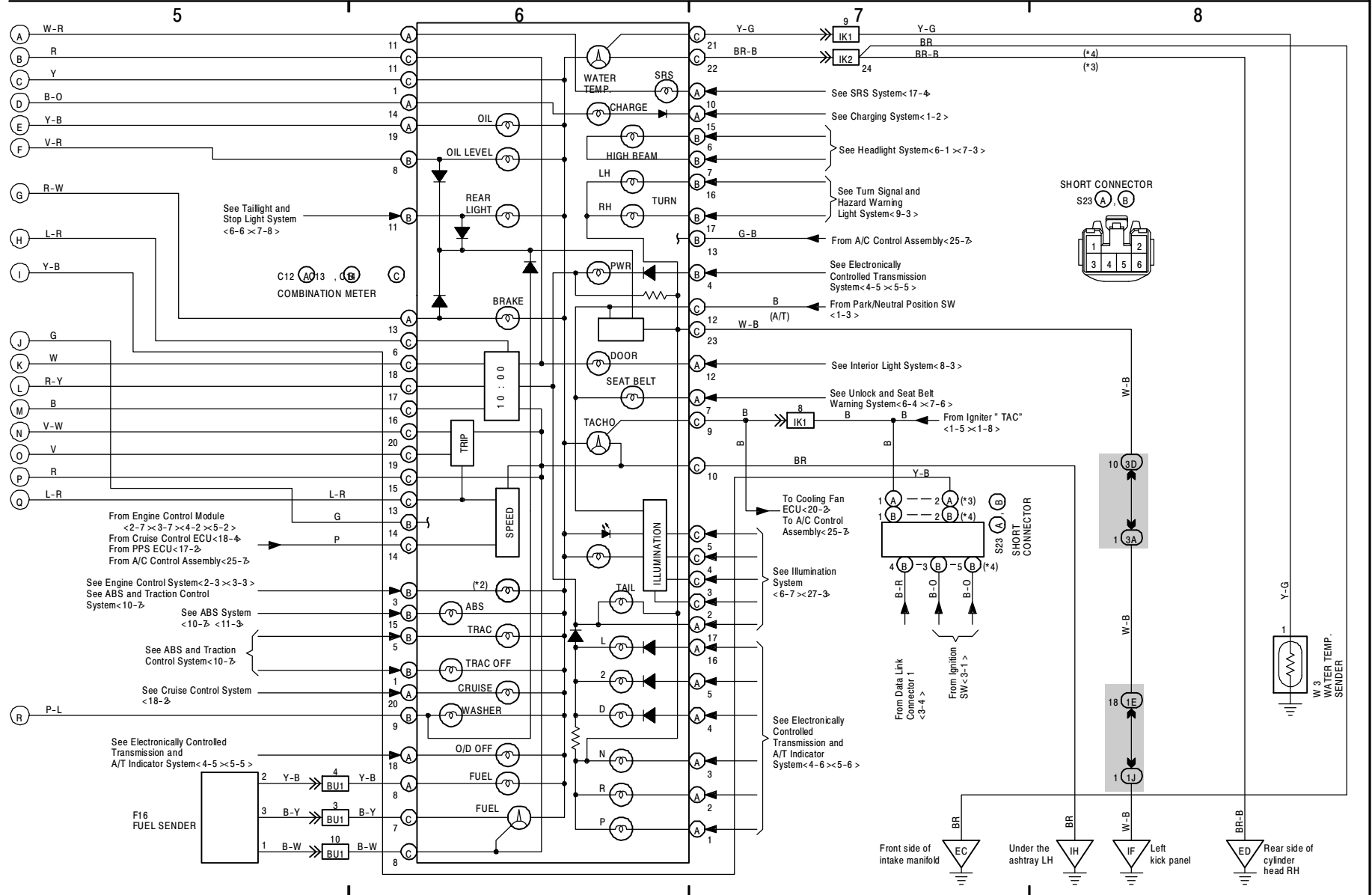

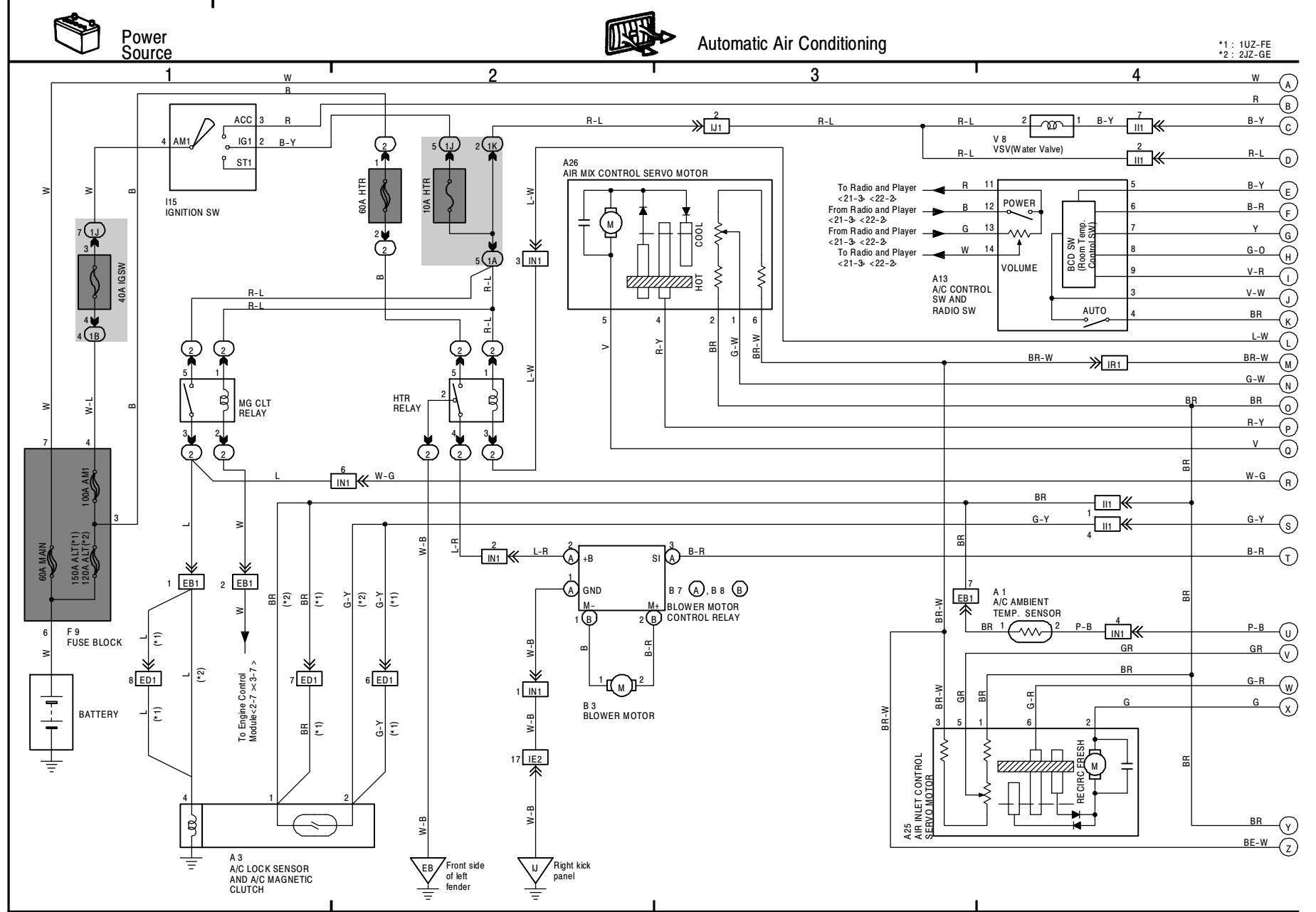



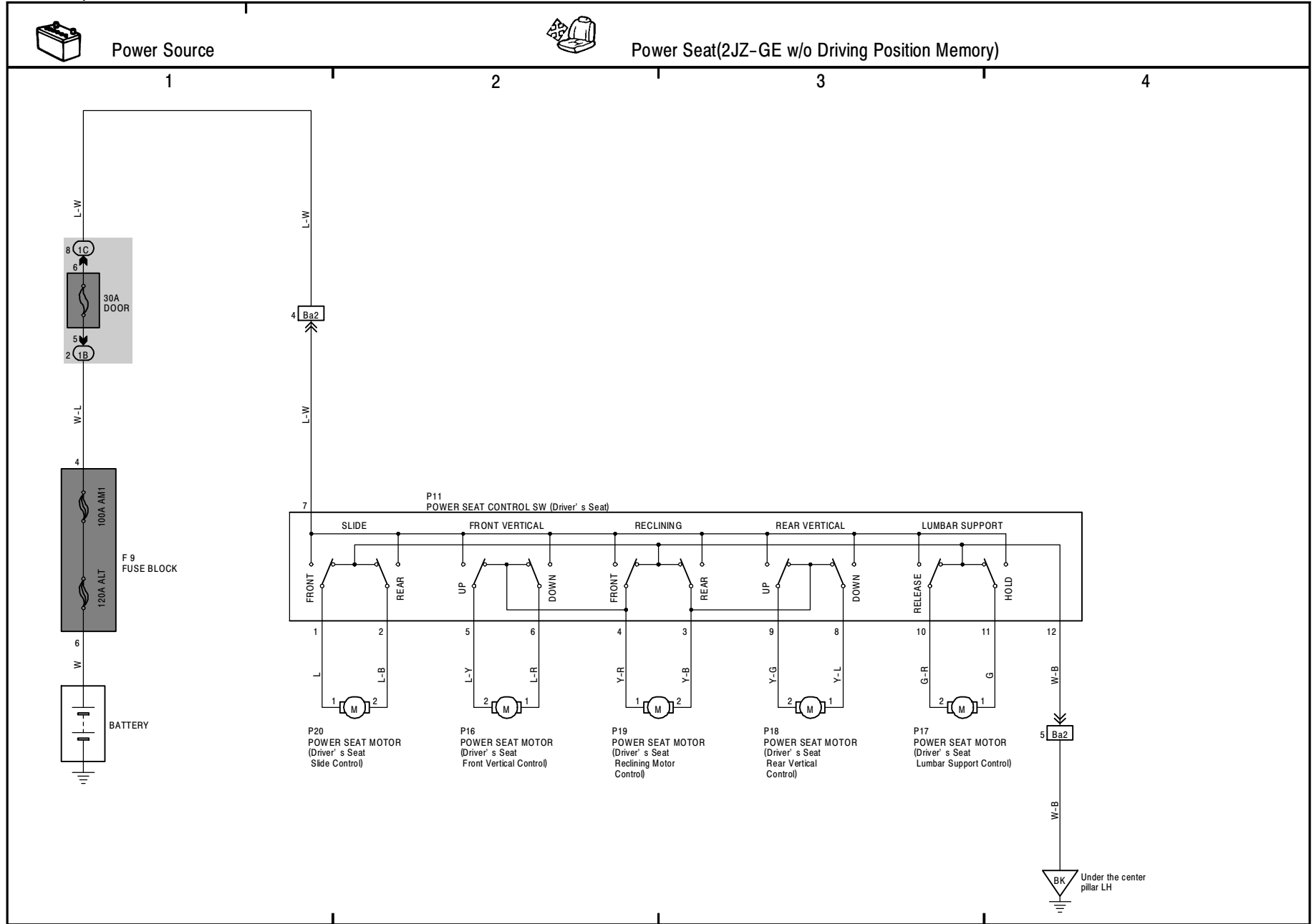



Power Source



Illumination (Canada)

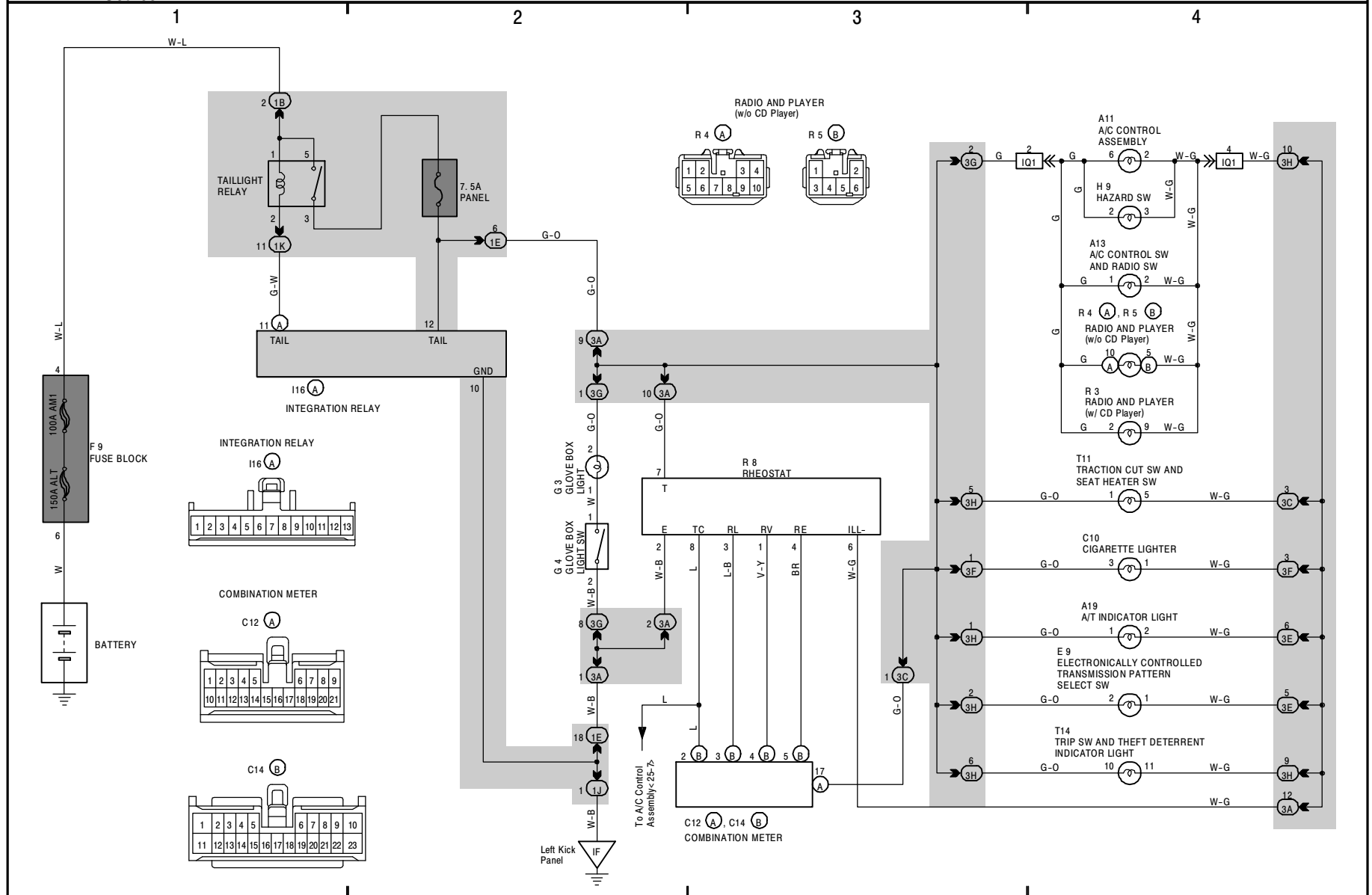

28 SC400/SC300

K OVERALL ELECTRICAL WIRING DIAGRAM

